

BLÜCHER Product Catalog

Stainless Steel Drainage Systems, Pipe & Channels

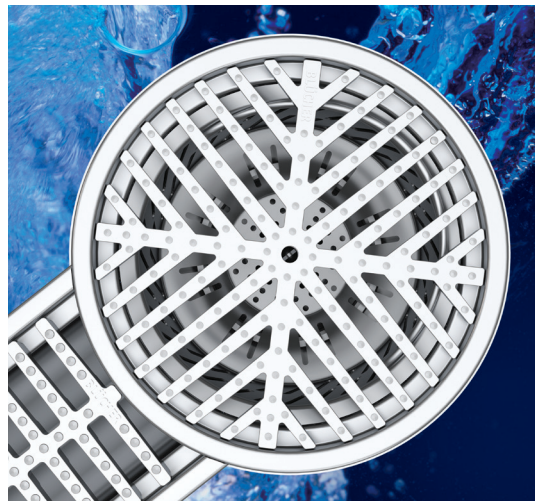

Table of Contents

Terms & Conditions of Sale	2
Pipe	3-30
Pictorial Index.	4-7
Technical Information	8-20
Pipe	21
Fittings	22-28
Marine Fittings	29-32
Pipe Accessories	33-36
Drains.	37-68
Pictorial Index.	38-41
Installation Examples.	42
Washroom/Shower Drains	43-44
Adjustable Floor Drains	45-46
On-Grade Adjustable Floor Drains.	47-48
Sanitary Floor Drains.	49-52
Floor Drains w/Surface Membrane Clamp	53-54
Floor Drains w/Elastomeric Flange	55
HygienicPro® Floor Drains	56
Gastight Industrial Drains	57
Hub Drains/Trap Primer Adaptors	58
Floor Drain Accessories	59-61
Floor Cleanouts	62-63
Marine Drains.	64-68
Channels	69-77
Pictorial Index.	70
Installation Examples.	71
Waterline Shower/Washroom Channels.	72
Trench Drains	73-74
Trench Drain Gratings	75
Kitchen Channels	76-77

BLÜCHER Terms & Conditions

FREIGHT TERMS:

Shipments from the factory of less than \$5,000.00 net are F.O.B. factory. Factory shipments over \$5,000.00 net will be prepaid and allowed within the continental United States when made at the lowest motor carrier transportation rate.

TERMS OF SALE:

All sales within the United States or within Canada are F.O.B. (shipping point). All international sales are F.O.B. (origin port).

PAYMENT TERMS:

Invoices are due and payable 30 days from the date of invoice. A 2% cash discount is allowed on net amount of invoice if paid on or before the 10th of the following month. Invoices dated on or after the 25th will be considered as dated the first of the next month.

PURCHASE ORDER FORMS:

Orders submitted on customer's own purchase order forms will be accepted only with the express understanding that no statements, clauses, or conditions contained in said order form will be binding on the seller if they in any way modify the seller's own terms and conditions of sales.

STOCKING WHOLESALE MINIMUM CHARGE:

A minimum billing charge of \$75.00 applies to shipments F.O.B. factory. Stocking Wholesaler Customers are encouraged to order sufficient material to avoid this charge which is necessitated by increased costs of processing small orders.

SPECIAL PRODUCTS:

Orders for special or modified products are non-cancelable and non-returnable. In the event that the customer cancels an order for such products, BLÜCHER shall charge the customer an amount equal to BLÜCHER'S costs and expenses incurred in performing the purchase order prior to receipt of notice of cancellation.

LIMITED WARRANTY:

BLÜCHER (the "Company") warrants each product to be free from defects in material and workmanship under normal usage for a period of one year from the date of original shipment. In the event of such defects within the warranty period, the Company will, at its option, replace or recondition the product without charge.

THE WARRANTY SET FORTH HEREIN IS GIVEN EXPRESSLY AND IS THE ONLY WARRANTY GIVEN BY THE COMPANY WITH RESPECT TO THE PRODUCT. THE COMPANY MAKES NO OTHER WARRANTIES, EXPRESS OR IMPLIED. THE COMPANY HEREBY SPECIFICALLY DISCLAIMS ALL OTHER WARRANTIES, EXPRESS OR IMPLIED, INCLUDING BUT NOT LIMITED TO THE IMPLIED WARRANTIES OF MERCHANTABILITY AND FITNESS FOR A PARTICULAR PURPOSE.

The remedy described in the first paragraph of this warranty shall constitute the sole and exclusive remedy for breach of warranty, and the Company shall not be responsible for any incidental, special or consequential damages, including without limitation, lost profits or the cost of repairing or replacing other property which is damaged if this product does not work properly, other costs resulting from labor charges, delays, vandalism, negligence, fouling caused by foreign material, damage from adverse water conditions, chemical, or any other circumstances over which the Company has no control. This warranty shall be invalidated by any abuse, misuse, misapplication, improper installation or improper maintenance or alteration of the product.

Some States do not allow limitations on how long an implied warranty lasts, and some States do not allow the exclusion or limitation of incidental or consequential damages. Therefore the above limitations may not apply to you. This Limited Warranty gives you specific legal rights, and you may have other rights that vary from State to State. You should consult applicable state laws to determine your rights. SO FAR AS IS CONSISTENT WITH APPLICABLE STATE LAW, ANY IMPLIED WARRANTIES THAT MAY NOT BE DISCLAIMED, INCLUDING THE IMPLIED WARRANTIES OF MERCHANTABILITY AND FITNESS FOR A PARTICULAR PURPOSE, ARE LIMITED IN DURATION TO ONE YEAR FROM THE DATE OF ORIGINAL SHIPMENT.

RETURNED GOODS RESTOCKING CHARGE:

No material shall be returned without authorization. When credit is issued it will be at the price charged, or prevailing price if lower, less handling charges based on costs of reconditioning, boxing, etc. However, a minimum 25% handling charge will apply. A minimum handling charge of \$35.00 is applied whenever the 25% handling deduction does not total \$35.00. Products which are obsolete or made to special order are not returnable.

NOTE:

Prices and terms are subject to change without notice and supersede all previous quotations. BLÜCHER reserves the right to change or modify product design or construction without prior notice and without incurring any obligation to make such changes and modifications on products previously or subsequently sold. All dimensions shown in this catalog are subject to manufacturing tolerances.

See your **BLÜCHER** representative for any clarification.

Stainless steel DWV pipe and fittings for commercial, industrial, and marine applications



Specifically engineered for DWV systems
Labor saving push-fit connections
Hygienic, lightweight, fire resistant

Installation

- Above or below ground
- Gravity or vacuum applications
- High-temperature drainage

Specifications

- Stainless steel AISI 316L / EN 1.4404
- Metric Equivalent diameters 1-1/2"(40) to 10"(250)
- Stock Lengths 6"(150) to 10'(3000)
- Full range of fittings
- Shipped with push-fit seals

Approvals

BLÜCHER operates its own testing facilities and is in cooperation with N. American and international approval institutions. BLÜCHER has played an active role in the development of international standards for stainless steel piping systems.

BLÜCHER products are designed and tested in accordance with ASME A112.3.1 and carry Uniform Plumbing Code (UPC) listings with IAPMO and NSF International in N. America. In addition, BLÜCHER products are widely certified internationally and in local N. American jurisdictions.

Pictorial Index



Px-xxx-316
Straight Pipe
w/One Socket



Bx-15-316
15° Bend



Bx-30-316
30° Bend



Bx-45-316
45° 1/8 Bend



Bx-90-316
90° 1/4 Bend



Bx-90S-316
90° Sweep 1/4
Bend



Txxx-90-316
90° Tee



Cxxx-90-316
90° Double Tee



DTxxx-90-316
90° Double Offset
Tee



SSxxx-90-316
90° Sanitary Sweep



WB-xxx-90-316
45° Combination
Wye & 1/8 bend



Wxxx-45-316
45° Wye



DWxxx-45-316
45° Double Wye



OWxxx-45-316
45° Double Offset
Wye



AP-x-316
Straight Access
Pipe



AT-xxx-316
90° Access Tee

Pictorial Index



AB-x-316
90° Access Bend



DC-x-316
Double Coupling



DSC-x-316
Double Slip Coupling



ES-x-316
Expansion Socket



LES-x-316
Long Expansion Socket



EI-xxx-316
Eccentric Increaser



CI-xxx-316
Concentric Increaser



ER-xxx-316
Eccentric Reducer



FA-xxx-316
Female Adaptor



MA-xxx-316
Male Adaptor



CS/ESIA-xxx-316
Side Inlet Adaptor



821.xxx.xxxS
90° Long
Radius Bend

Marine



854.2/300.xxxS
DIN Socket
Flange Adaptor

Marine



854.2/310.xxxS
DIN Spigot
Flange Adaptor

Marine



854.025.xxxS
ANSI Socket
Flange Adaptor

Marine

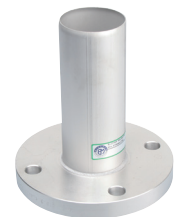

854.035.xxxS
ANSI Spigot
Flange Adaptor

Marine

Pictorial Index

Marine



855.090.xxxS
Toilet Adaptor

Marine



866.025.xxx.10FS
Bulkhead Penetration
w/Welding Sleeve

Marine



866.032.050.055
Wash Basin Penetration
w/Welding Sleeve

Marine



867.020.xxx.105
Toilet Penetration for Vacuum
System w/Welding Sleeve

Marine



868.xxx.xxxFS
Deck Penetration
with Welding Flange

Marine



870.000.xxxFS
Socket Deck
Penetration

Marine



872.xxx.xxxS
Deck Penetration
with Welding Sleeve

Marine



878.xxx.xxxS
Aluminum Deck Penetration
w/Bi-Metal Welding Flange



EPDM/FPM/NBR
Sealing Rings



BTC-xxx
Transition Coupling



PT-x-316
P-Trap



PTC-xxx-316
P-Trap w/Coupling



PT-L
Long Sweep P-Trap



BT-x
Bottle Trap



TA-1-1/2x2-316
Tailpiece Adaptor



JC-x
Joint Clamp

Pictorial Index



PH-x
Pipe Hanger



PH-2-x
2-Piece Pipe Hanger



PHA-x
Adjustable Pipe Hanger



SB-1
Sway Brace



PSP-x
Push-In Socket Plug



CSP-x
Compression Socket Plug



MPC-xxx
Manual Pipe Cutter



EPC-2-6
Electric Pipe Cutter



CO-1
Cutting Oil



JL-1
Jointing Lubricant



DJ-1
Dimpling Tool

Above Ground Installation

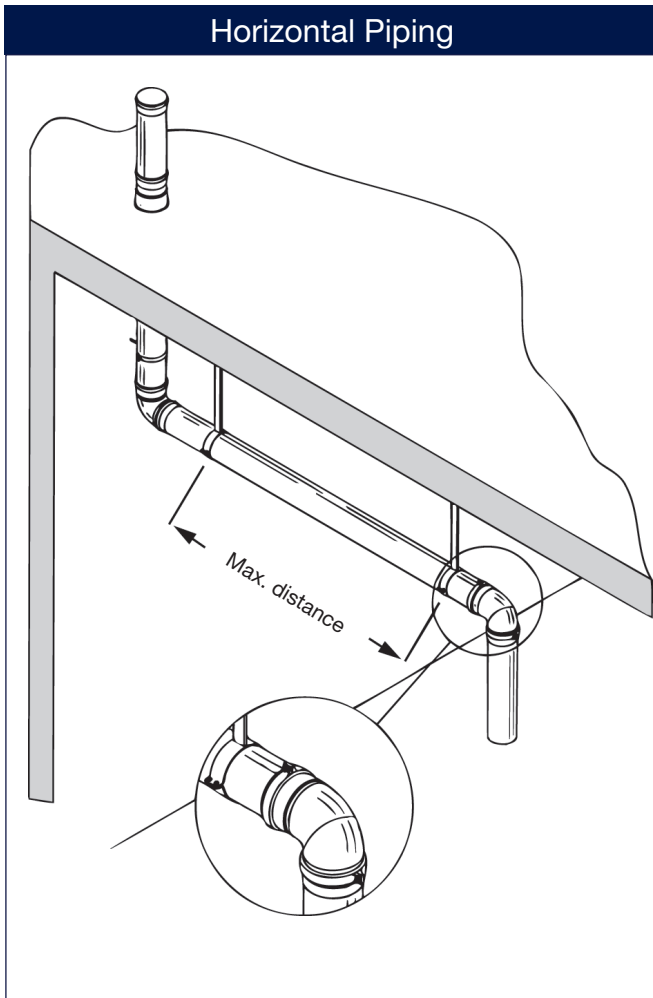

Maximum Distance

<i>Dia</i>	<i>Distance Between Supports</i>
2"	7' (2.2m)
3"	8' (2.5m)
4"	9' (2.8m)
5"	10' (3m)
6"	11' (3.3m)
8"	11' (3.3m)
10"	10' (3.0m)

Horizontal pipe runs are always to be installed with a gradient. If no self-cleansing calculation is available, a gradient of 1/8"/ft. is recommended in gravity systems. Horizontal pipe runs in vacuum systems are to be installed in accordance with the recommendations of the vacuum system supplier.

When connecting major branch lines, the pipe is to be fixed just below the branch line.

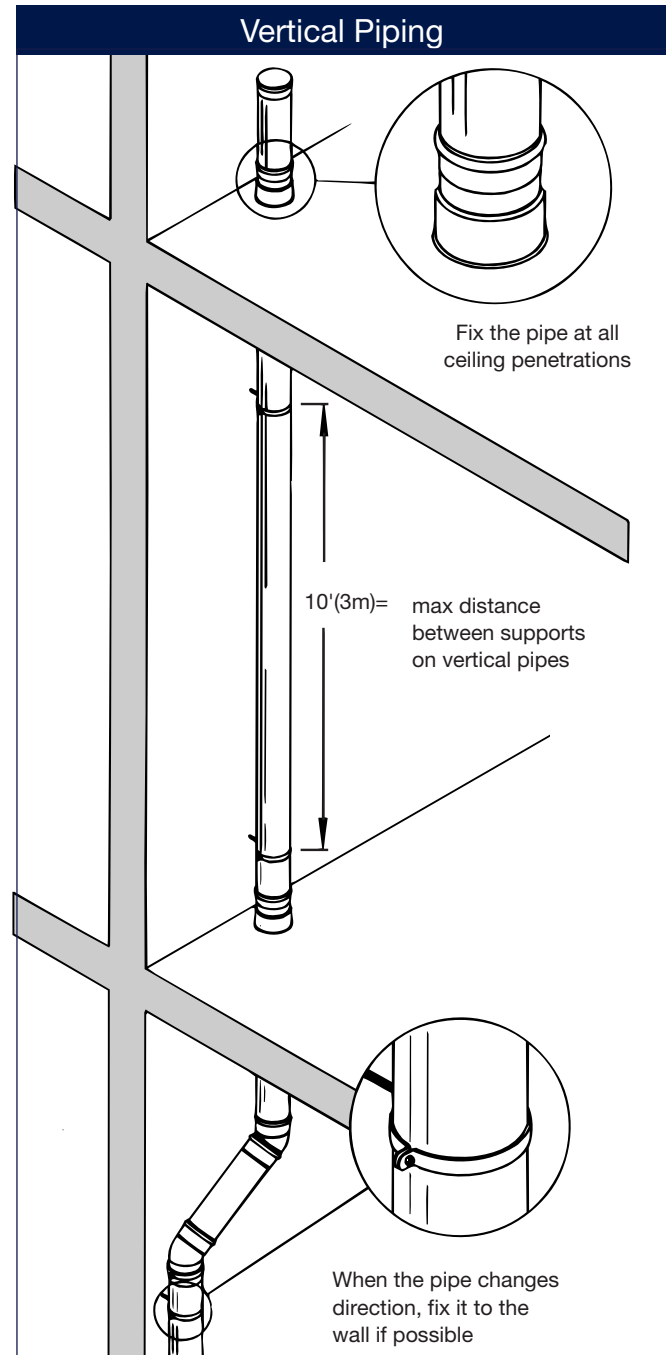

One fixing point per story is normally sufficient. Stainless steel piping requires only one pipe hanger per 10'(3m), resulting in labor savings and faster installation.

Consult BLÜCHER for additional Pipe technical or installation information.

Below Ground Installation

RECOMMENDED MINIMUM SOIL COVERING

- pipe below water table (terrain = water table)
- soil compressed to 93% SP
- $\gamma\text{-}\gamma' = 8 \text{ kN/m}^3$

Filling around the pipe

All piping and joints should be properly inspected and tested prior to filling. Soil from the excavation can be used for filling, but larger stones and blocks which may damage the pipe should not be used. Avoid tipping the fill directly onto the pipe. The filling should be compressed to at least 93%.

Recommended Minimum Soil Covering

4"(110) Pipe Traffic		6"(160) Pipe Traffic		8"(200) Pipe Traffic		10"(250) Pipe Traffic	
Normal	Heavy	Normal	Heavy	Normal	Heavy	Normal	Heavy
11"(.27m)	16"(.41m)	15"(.38m)	22"(.56m)	16"(.41m)	24"(.6m)	22"(.56m)	30"(.77m)

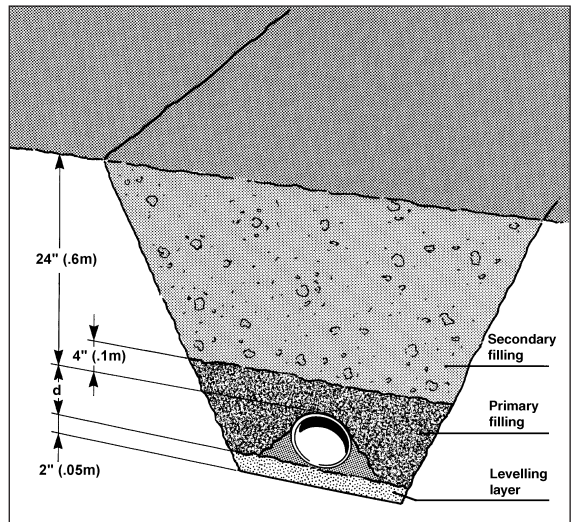
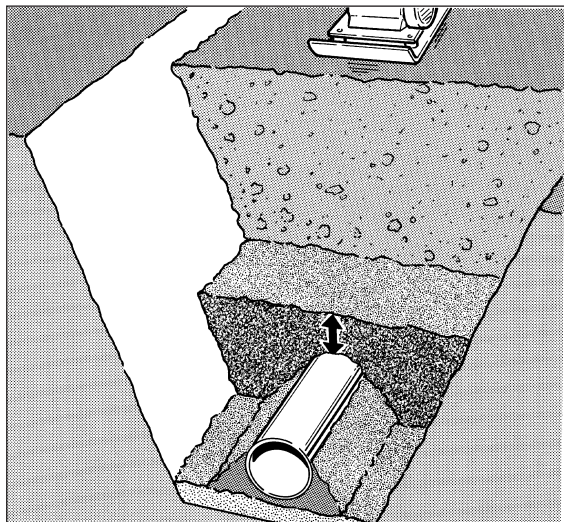
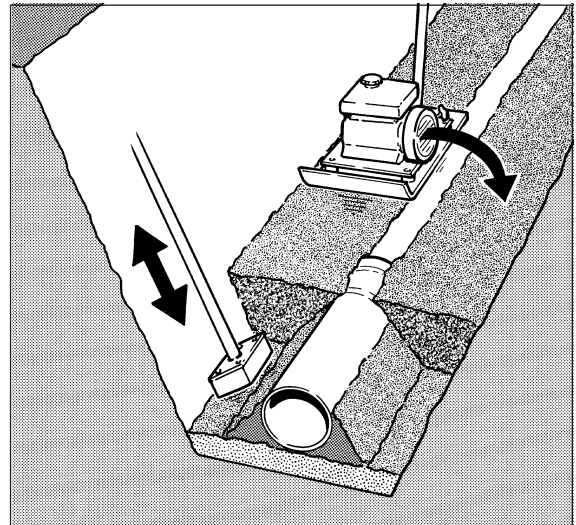
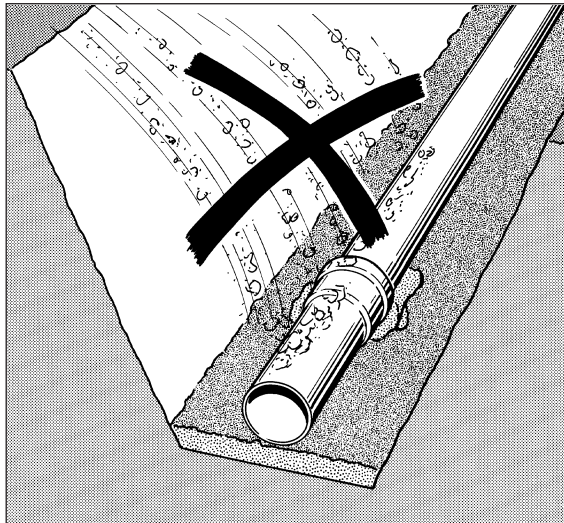

Material properties of stainless steel

What is stainless steel?

The designation stainless steel covers a wide range of alloys with different properties. One property common to all stainless steels is that they contain at least 12% chromium.

The stainless steels can be divided into three main groups and a few mixed types according to the structure of the steel:

- Austenitic stainless steel
- Ferritic stainless steel
- Martensitic stainless steel

Austenitic stainless steel is the most important, representing approx. 90% of total stainless steel consumption. Austenitic steel is also the only stainless steel suitable for drainage installations, and it is, of course, the type used by BLÜCHER.

Importance of alloying elements

Austenitic stainless steel contains at least 18% chromium and 8% nickel – thus the well-known designation »18/8« steel. Corrosion resistance generally increases with increasing content of chromium. In alloys with 12-13% chromium, the passive layer is strong enough to prevent the steel from corroding in normal or mildly aggressive media. The main effect of the alloying element nickel is on the structure of the steel and its mechanical properties. The steel's structure is austenitic with an adequate content of nickel. In contrast to the pure chromium steels (ferritic stainless steel), this results in significant changes in the mechanical properties, such as increased workability and ductility, better resistance to thermal stress and improved weldability. The austenitic structure also results in a change in the physical properties of the steel. For example, the steel is not magnetic and has higher thermal conductivity.

Material Specification

Material	AISI 316 L 1.4404	AISI 304 1.4301
Analysis		
Carbon (C %)	Max. 0.03	Max. 0.07
Chromium (Cr %)	16.5 - 18.5	17.0 - 19.0
Nickel (Ni %)	11.0 - 14.0	8.5 - 10.5
Molybdenum (Mo %)	2.0 - 2.5	-
Manganese (Mn %)	Max. 2.0	Max. 2.0
Silicium (Si %)	Max. 1.0	Max. 1.0
Sulphur (S %)	Max. 0.030	Max. 0.030

Physical Properties

Structure	Austenitic (nonmagnetic)	Austenitic (nonmagnetic)
State	Non-annealed	
Specific gravity (g/cm ³)	7.98	7.9
Melting point (°F)	Approx. 2550	Approx. 2550
Decortication temperature in air (°F)	1472 - 1580	1472 - 1580
Expansion coefficient 20 - 100°C (m/m · °C)	16.5 x 10 ⁻⁶	16.5 x 10 ⁻⁶
Specific resistance (20°C) (Ohm · mm ² /m)	0.75	0.73
Heat conductivity (20°C) (W/°C-m)	15	15
Specific heat (J/g · k)	0.5	0.5

Mechanical Properties

Ultimate tensile strength (Rm) (N/mm ²)	490 - 690	500 - 700
Yield point (Rpo2) (N/mm ²)	190	195
Modulus of elasticity (E) (20°C) (N/mm ²)	2.0 x 10 ⁵	2.0 x 10 ⁵
Hardness Brinell (HB) (N/mm ²)	120 - 180	130 - 180

Nickel also increases resistance to corrosion caused by certain media. Molybdenum has the same effect on the structure as chromium, but it also has a strongly positive influence on corrosion resistance. Molybdenum-containing steel is normally designated »acid-resistant« because of the resistance of these steels to certain types of acids. But acid-resistant stainless steel will also have limited resistance to some media such as chlorine-containing media (see table of resistance).

Why is steel "stainless"?

The addition of chromium to the steel results in the formation of a passivating oxide film with a high content of chromium oxides.

This oxide film protects the surface of the steel against oxygen in air and water. An outstanding property of stainless steel is that the chromium oxide film automatically regenerates if the surface of the steel is exposed.

This restitution of the oxide film can only occur if the surface of the steel is completely clean and free of tempering agents and slag from welding processes and residues from tools made from ordinary carbon steel.

If this surface contamination is not removed, the steel may ultimately corrode. To prevent this, the steel surfaces should be cleaned after welding and processing, e.g. by means of so-called acid pickling of the stainless steel.

The pickling effectively removes all impurities from the surface of the steel and permits the reestablishment of a strong, uniform chromium oxide film. The pickling bath normally consists of 0.5-5% v/v HF (hydrofluoric acid) and 8-20% v/v HNO₃ (ni-tric acid) at a temperature of 77-140°F. This acid bath removes residues, the existing chromium oxide film and traces of iron, leaving the clean steel surface. The restitution of a strong chromium oxide film starts in the subsequent rinsing in water.

Material properties of joint sealing rings

Rubber types

International designation	EPDM	NBR	FPM
Rubber type	Ethylene propene	Nitrile	Fluorine (Viton)
Nominal hardness IRHD	60 (+/-5)	60 (+/-5)	60(+/-5)
Color	Black	Black/yellow dot	Purple
Tensile strength MPa	≥ 10 N/mm ²	≥ 10 N/mm ²	≥ 8 N/mm ²
Elongation after fracture %	≥ 300%	≥ 300%	≥ 260%
Max. temperature range	-31/+212°F	-22/+176°F	-13/+392°F

Resistance

Wearability	B	B	B
Resistance to mineral oil	D	A	A
Resistance to vegetable oil	B	A	A
Resistance to benzene/petrol	D	A	A
Resistance to aromatic compounds and hydrocarbons	D	B	A
Resistance to ketones	A	D	D
Resistance to ordinary diluted acids and alkalines	A	A	A
Resistance to ozone and weather stresses	A	C	A
Resistance to air diffusion	D	C	A

A = Very good service - B = Moderate service - C = Limited or variable service - D = Unsatisfactory

A joint sealing ring constitutes the seal between socket and spigot end. The joint sealing ring ensures quick and efficient jointing of the pipe system while providing a tight seal in case of both pressure and vacuum. BLÜCHER® sealing rings are available in three different rubber qualities.

EPDM This standard sealing ring is black and made from ethylene propene rubber. It is suitable for all rain-water and waste water installations which do not contain significant petroleum residues.

NBR This sealing ring is black with a yellow spot and made from nitrile rubber. NBR rings should be specified for installations where oil or petroleum products are present. NBR is not resistant to solvents, and should not be used where temperatures may exceed 176°F.

FPM This sealing ring is green or purple, and made from fluorine rubber (Viton®). FPM sealing rings should be specified for high temperature applications. They are resistant to oil, solvents, and strong acids.

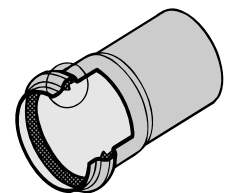
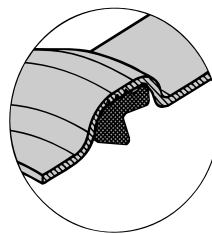

CHEMICAL RESISTANCE TABLE

INTRODUCTION

When dealing with aggressive fluids the user is continuously faced with the problem of finding compatible materials.

In order to simplify the selection of suitable materials when using BLÜCHER products for aggressive fluids, the following tables provide useful information on the optimal choice of the stainless steel grade and gasket material for a multitude of media.

Since corrosion performance is influenced by several factors, the information contained in this document should be treated only as a guide and is not necessarily valid for all operating conditions. Increased temperatures, higher concentrations, and the inadvertent ingress of water in originally pure chemicals can all lead to accelerated corrosion.

STRUCTURE AND CONTENT OF THE CHEMICAL RESISTANCE CHARTS

The following chemical resistance tables are divided into three categories. These are basic chemicals, liquid commercial products, and liquid food ingredients.

The resistance of these fluids is rated in detail for the materials commonly used in BLÜCHER products.

For the most commonly used chemical substances the chemical formula is added in the charts. The suffix "pure" means the technical pureness of the fluid, which in most cases exceeds 95% purity.

The information quoted in this guide does not consider the effect of mechanical loading, which may also have a bearing on the material performance in the fluid. In cases of doubt when considering BLÜCHER products, we strongly recommend the prior testing of material samples in order to establish and check their suitability under the actual operating conditions of the application.

Where liquid food products are involved, the plastics and elastomers employed must normally conform with the local food and hygiene regulations. It is emphasised that these resistance tables are intended only as a guide, and that no guarantees can be given in respect of the information contained in this publication.

BLÜCHER does not assume any liability for your selection. No claims on the basis of an incorrect advice can be made from the use of the Chemical Resistance Chart. Neither warranty claims, guarantee claims, nor claims for damages can be derived. We also reserve the right to change, update, or modify all information in this chart without notice.

As a rule, organic fluidic or gaseous media have this supplement. "Acetic acid - pure" means for example a 98% acetic acid. The suffix "aqueous" is mostly used for water miscible substances (such as Ethanol) but also for aqueous solutions of inorganic salts.

Due to the great number of possible concentrations, an average concentration is always assumed. Saturated aqueous solutions are described only if explicitly noted and the reference temperature for all statements is room temperature. At higher temperatures a reduced chemical resistance must be considered.

CHEMICAL RESISTANCE TABLE

Interpretation of Symbols + material is not affected or is slightly affected by the chemical: suitable O various attack level depending on prevailing conditions: limited suitability - material exhibits severe attack: unsuitable	FORMULA	NBR	EPDM	FPM	AISI 316L	AISI 304
A						
Acetaldehyde – aqueous	CH ₃ CHO	-	+	O	+	+
Acetaldehyde – pure	CH ₃ CHO	-	+	-	+	+
Acetic acid – pure	CH ₃ COOH	-	O	-	O	O
Acetic anhydride – pure	CH ₃ COOCOCH ₃	-	O	-	O	O
Acetoacetic ester (acid-free) – pure	CH ₃ COCH ₂ COOC ₂ H ₅	-	-	-	+	+
Acetone – pure	CH ₃ COCH ₃	-	+	-	+	+
Acetophenone – pure	C ₆ H ₅ COCH ₃	-	-	-	+	+
Acetylacetone – pure	CH ₃ COCH ₂ COCH ₃	-	-	-	+	+
Acetylchloride – pure	CH ₃ COCl	-	-	-	O	O
Acetylene – technical	HCCCH	-	+	-	+	+
Acrylonitrile – pure	CH ₂ CHCN	-	-	-	+	+
Adipic acid – aqueous	HOOC(CH ₂) ₄ COOH	+	+	+	+	+
Albumin – pure		+	+	+	+	+
Allyl alcohol – pure	CH ₂ CHCH ₂ OH	+	+	O	+	+
"Alum (potassium aluminium sulphate) – aqueous"	KAl(SO ₄) ₂ x 12 H ₂ O	+	+	+	+	O
Aluminium acetate – aqueous	Al(OOCCH ₃) ₃	O	+	+	+	+
Aluminium chloride – aqueous	AlCl ₃	+	+	+	O	O
Aluminium fluoride – aqueous	AlF ₃	+	+	+	-	-
Aluminium sulphate – aqueous	Al(SO ₄) ₃	+	+	+	O	O
Aminoacetic acid (glycine) – aqueous	NH ₂ CH ₂ COOH	O	+	+	+	+
Ammonia (gaseous) – pure	NH ₃	-	+	O	+	+
Ammonia (liquid) – pure	NH ₃	-	O	O	+	+
Ammonia water (ammonia solution, ammonium hydroxide)	NH ₃ OH	-	+	O	+	+
Ammonium acetate – aqueous	CH ₃ COONH ₄	+	+	+	+	+
Ammonium carbonate – aqueous	(NH ₄) ₂ CO ₃	+	+	+	+	+
Ammonium chloride – aqueous	NH ₄ Cl	+	+	+	O	O
Ammonium citrate – aqueous		+	+	+	+	+
Ammonium fluoride – aqueous	NH ₄ F	+	+	+	O	O
Ammonium fluosilicate – aqueous		+	+	+	+	+
Ammonium formate – aqueous	HNCOONH ₄	+	+	+	+	+
Ammonium hydroxide (ammonia solution, ammonia water) – aqueous	NH ₃ OH	-	+	O	+	+
Ammonium nitrate – aqueous	NH ₄ NO ₃	+	+	+	+	+
Ammonium oxalate – aqueous	NH ₄ OOC ₂ COONH ₄	+	+	+	+	+
Ammonium persulphate – aqueous	(NH ₄) ₂ S ₂ O ₈	-	+	+	O	O
Ammonium phosphate – aqueous	(NH ₄) ₂ HPO ₄	+	+	+	+	+
Ammonium sulphate – aqueous	(NH ₄) ₂ SO ₄	+	+	+	O	O
Ammonium sulphide – aqueous	(NH ₄) ₂ S	+	+	O	+	+
Ammonium sulphite – aqueous	(NH ₄) ₂ SO ₃	+	+	+	+	+
Ammonium thiocyanate – aqueous	NH ₄ NCS	+	+	+	+	+
Amyl acetate – pure	CH ₃ COO(CH ₂) ₄ CH ₃	-	O	-	+	+
Amyl alcohol – pure	H ₃ C(CH ₂) ₄ OH	+	O	+	+	+
Aniline hydrochloride – aqueous	C ₆ H ₅ NH ₂ Cl	O	+	O	-	-
Aniline – pure	C ₆ H ₅ NH ₂	-	O	O	+	+
Anisole (methoxybenzene) – pure	C ₆ H ₅ OCH ₃	O	O	-	+	+
Anone (cyclohexanone) – pure	C ₆ H ₁₀ O	-	-	-	+	+
Anthracene oil – pure		-	-	-	+	+
"Anthraquinone sulphonic acid – aqueous"	C ₆ H ₄ COCOC ₆ H ₄ SO ₃ H	O	+	+	O	O
Antimony chloride – aqueous	SbCl ₃	O	+	+	-	-
Aqua regia	HNO ₃ + HCl	-	-	-	-	-
Arabic acid – aqueous		+	+	+	+	+
Argon – pure	Ar	+	+	+	+	+
Arsenic acid – aqueous	H ₃ AsO ₄	+	+	+	+	+
Arsenic trichloride – aqueous	AsCl ₃	+	+	+	O	O
Arsenious acid – aqueous	H ₃ AsO ₃	+	+	+	+	+
Arylsilicate – aqueous	O	O	O	+	+	+
Ascorbic acid – aqueous	C ₆ H ₈ O ₆	+	+	+	+	+
Aspartic acid – aqueous	HOOCCHNH ₂ CH ₂ -COOH	+	+	+	+	+
B						
Barium chlorate – aqueous	Ba(ClO ₂) ₂	+	+	+	+	+
Barium chloride – aqueous	BaCl ₂	+	+	+	+	O
Barium hydroxide – aqueous	Ba(OH) ₂	+	+	+	+	+
"Barium sulphide and polysulfide – aqueous"	BaS	+	+	+	+	+
Battery acid (sulphuric acid 20%)	H ₂ SO ₄	O	+	+	+	O
Benzaldehyde – aqueous	C ₆ H ₅ CHO	O	+	+	+	+
Benzene – pure	C ₆ H ₆	-	-	-	+	+
Benzenesulfonic acid – aqueous	C ₆ H ₄ SO ₃ H	+	+	+	+	+
Benzidine sulphonic acids – aqueous	NH ₂ C ₆ H ₄ C ₆ H ₄ -SO ₃ NH ₂	+	+	+	+	+
Benzene (heptane, hexane) – pure		+	-	+	+	+
Benzoic acid – aqueous	C ₆ H ₅ COOH	+	+	+	+	+
Benzyl alcohol – pure	C ₆ H ₅ CH ₂ OH	-	+	O	+	+
Bergamot oil		-	-	-	+	+

Interpretation of Symbols + material is not affected or is slightly affected by the chemical: suitable O various attack level depending on prevailing conditions: limited suitability - material exhibits severe attack: unsuitable	FORMULA	NBR	EPDM	FPM	AISI 316L	AISI 304
C						
"Bisulphite (sodium bisulphite, sodium hydrogen sulphide) – aqueous"	NaHSO ₃	O	+	+	+	O
Borax – aqueous	N ₂ B ₂ O ₇	+	+	+	+	+
Boron hydrofluoric acid (fluoroboric acid) – pure	HF ₃	+	+	+	-	-
Boric acid – aqueous	H ₃ BO ₃	+	+	+	O	O
Brine (cooling brine)		+	+	+	O	O
Bromine (liquid) – pure	Br ₂	-	-	-	O	O
Butadiene – pure	CH ₂ (CH)=CH ₂	O	O	O	+	+
Butane (gaseous and liquid) – pure	C ₄ H ₁₀	+	-	+	+	+
Butanediol – aqueous (10%)	HO(CH ₂) ₂ OH	+	+	O	+	+
Butanol (butyl alcohol) – pure	CH ₃ (CH ₂) ₂ OH	O	+	+	+	+
Butoxyl (methoxybutyl acetate) – pure	CH ₃ OC ₂ H ₄ O ₂ CCH ₃	+	O	O	+	+
Butyl acetate – pure	CH ₃ (CH ₂) ₃ O ₂ CCH ₃	O	+	-	+	+
Butyl alcohol (butanol) – pure	CH ₃ (CH ₂) ₂ OH	-	+	+	+	+
Butylbenzyl phthalate – aqueous		-	-	-	+	+
Butylene (liquid) – pure	H ₂ CCH ₂ CHCH ₂	+	O	+	+	+
Butyl phthalate – pure	C ₆ H ₄ (CO ₂) ₂ (O(CH ₂) ₃) ₂	-	-	-	+	+
Butynediol – pure	HOCH ₂ C≡CCH ₂ OH	O	O	O	O	+
Butyric acid – aqueous	H ₃ C(CH ₂) ₂ COOH	O	O	O	+	O
C						
Calcium chloride – aqueous	CaCl ₂	+	+	+	O	O
Calciumhydrogensulphate – aqueous	Ca(HSO ₄) ₂	+	+	+	+	O
"Calcium hydroxide (lime water) – aqueous"	Ca(OH) ₂	+	+	+	+	+
"Calcium hypochlorite (chlorinated lime) – aqueous"	Ca(OCl) ₂	-	+	O	O	O
Calcium nitrate – aqueous	Ca(NO ₃) ₂	+	+	+	O	O
"Carbitol (2-(2-ethoxyethoxy)ethanol) – pure"	CH ₃ CH ₂ O(CH ₂) ₂ -O(CH ₂) ₂ OH	O	O	O	+	+
Carbolineum (creosote) – pure	O	O	O	+	+	+
"Carbolic acid (phenol, hydroxybenzene) – aqueous"	C ₆ H ₅ OH	O	O	O	+	+
Carbon dioxide (dry) – pure	CO ₂	+	O	+	+	+
Carbon dioxide (humid)	CO ₂	+	O	O	+	+
Carbon disulphide – pure	CS ₂	-	-	+	+	O
Carbonic acid – aqueous	H ₂ CO ₃	+	+	+	+	+
"Carbonyl chloride (phosgene) [liquid] – pure"	COCl ₂	-	O	+	+	+
"Carbonyl chloride (phosgene) [gaseous] – pure"	COCl ₂	-	+	+	+	+
Carbon monoxide – pure	CO	+	+	+	+	+
Carbon tetrachloride – pure	CCl ₄	-	-	-	+	+
"Caustic potash (potassium hydroxide) – aqueous"	KOH	-	+	-	+	+
Cellosolve (glycol ethyl ether) – pure	HO(CH ₂) ₂ OCH ₂ CH ₃	-	-	-	+	+
Champhor oil – pure		-	+	+	+	+
Chloral hydrate (chloral) – aqueous	CCl ₃ CH(OH) ₂	-	O	O	O	O
Chloric acid – aqueous	HClO ₃	-	O	-	-	-
"Chlorinated lime (calcium hypochlorite) – aqueous"	Ca(OCl) ₂	-	+	O	O	O
"Chlorine bleaching lye (sodium hypochlorite) – aqueous"	NaOCl	-	O	O	O	O
Chlorine dioxide – aqueous	ClO ₂	-	-	O	O	O
Chlorine (gaseous and dry)	Cl ₂	-	-	O	O	O
Chlorine (gaseous and humid)	Cl ₂	-	-	O	-	-
Chlorine (liquid) – pure	Cl ₂	-	-	O	+	+
Chlorine water (humid)	Cl ₂	-	-	O	-	-
Chloroacetic acid – aqueous	ClCH ₂ COOH	-	O	-	O	-
Chlorobenzene – pure	C ₆ H ₅ Cl	-	-	-	+	+
"Chloroethanol (ethylene chlorohydrine) – pure"	ClCH ₂ CH ₂ OH	-	-	O	+	+
Chlorofluorocarbons (frigenes)						
Chloroform (trichloromethane) – pure	CHCl ₃	-	-	O	+	+
Chloromethane (methyl chloride) – pure	CH ₃ Cl	-	-	O	+	+
Chloronaphthalene – pure	C ₁₀ H ₇ Cl	-	-	O	+	+
Chlorophenol – pure	C ₆ H ₄ OHCl	-	-	-	+	+
Chlorophenoxyacetic acid – aqueous	ClC ₆ H ₄ OCH ₂ COOH	+	+	+	+	+
Chlorosulfonic acid – pure	ClSO ₃ H	-	-	-	O	O
Chloroxylenol (4-Chloro-,5-dimethyl- phenol) – pure	C ₆ H ₃ OH(CH ₃) ₂ Cl	-	-	-	+	+
Choline chloride – aqueous	[HOCH ₂ CH ₂ N(CH ₃) ₃]Cl	+	+	+		



A WATTS Brand

CHEMICAL RESISTANCE TABLE

Interpretation of Symbols + material is not affected or is slightly affected by the chemical: suitable O various attack level depending on prevailing conditions: limited suitability - material exhibits severe attack: unsuitable	FORMULA					
		NBR	EPDM	FPM	AIISI 316L	AIISI 304
CHEMICALS						
Chrome alum (chromium(III) – potassium sulphate) – aqueous	$KCr(SO_4)_2 \times 12 H_2O$	+	+	+	O	O
Chromic acid – aqueous	H_2CrO_4	-	O	+	O	O
Chromium sulphate – aqueous	$Cr_2(SO_4)_3$	+	+	+	O	O
Citral (citronella oil) – pure		-	-	-	+	+
Citric acid – aqueous	$C_6H_8O_7$	+	+	+	+	O
Colophonium (tall oil) (liquid)		O	O	O	+	+
Cooling brine (brine)		+	+	+	O	O
Copper acetate – aqueous	$Cu(CH_3COO)_2$	O	+	+	+	+
Copper chloride – aqueous	$CuCl_2$	+	+	+	-	-
Copper sulphate – aqueous	$CuSO_4$	+	+	+	O	O
Cresote (carbolineum) – pure	O	O	O	+	+	+
Cresol – aqueous	$C_6H_5(OH)(CH_3)$	-	-	O	+	O
Cyclohexane – pure	C_6H_{12}	-	-	O	+	+
Cyclohexanol – pure	$C_6H_{11}OH$	-	-	+	+	+
Cyclohexanone (anone) – pure	$C_6H_{10}O$	-	-	-	+	+
Cymene – pure	$C_6H_4(CH_3)[CH(CH_3)_2]$	-	-	-	+	+
D						
Decahydronaphthalene (decalin) – pure	$C_{10}H_{18}$	-	-	+	+	+
Dextrose (glycose) – aqueous	$C_6H_{12}O_6$	+	+	+	+	+
Diacetone alcohol (anhydrous) – pure	$(CH_3)_2COHCH_2COCH_3$	-	+	-	+	+
Dibutyl phthalate – pure	$C_8H_{16}(COOC_4H_9)_2$	-	O	-	+	+
Dibutyl sebacate (DBS) – pure	" $(C_4H_9COO)(CH_2)_6(OOC_4H_9)$ "	-	O	-	+	+
"Dichloroethane (ethylene chloride) – pure"	$ClCH_2CH_2Cl$	-	-	-	+	-
Dichloroethene – pure	$Cl_2CHCHCl_2$	-	-	O	+	+
"Dichloromethane (methylene chloride) – pure"	CH_2Cl_2	-	-	O	+	+
Dicyclohexylammonium nitrate – pure	$[(C_6H_{11})_2NH_2]NO_2$	+	+	+	+	+
Diethyl ether (ether) – pure	$CH_3CH_2OCH_2CH_3$	-	-	-	+	+
Dimethylamine – pure	$(CH_3)_2NH$	-	O	-	+	+
Dimethylformamide (DMF) – pure	$HCON(CH_3)_2$	-	-	-	+	+
Dimethyl sulfoxide (DMSO) – pure	$(CH_3)_2SO$	-	-	-	+	+
Dinitrogen monoxide (laughing gas, nitrous oxide) – pure	N_2O	+	+	+	+	+
Di-octyl-phthalate (DOP) – pure	$C_8H_{16}(COOC_8H_{17})_2$	-	O	O	+	+
Dioxane – pure	$C_8H_{16}O$	-	O	-	+	+
Diphenyl + diphenyl oxide – pure		-	-	-	+	+
Dissous gas (acetylene + acetone)	$C_2H_2 + CH_3COCH_3$	-	+	-	+	+
E						
Essential oils		-	-	-	+	+
Ethane – pure	CH_3CH_3	+	-	+	+	+
Ethanedioic acid – aqueous (saturated)	$HOOC_2COOH$	O	+	+	+	O
Ethanol (ethyl alcohol) – pure	CH_3CH_2OH	O	+	O	+	+
Ethanolamine – pure	$NH_2CH_2CH_2OH$	O	O	-	+	+
Ether (diethyl ether) – pure	$CH_3CH_2OCH_2CH_3$	-	-	-	+	+
Ethyl acetate – pure	$CH_3CO_2CH_2CH_3$	-	O	-	+	+
Ethyl acrylate – pure	$CH_2=CHCOOC_2H_5$	-	O	-	+	+
Ethyl alcohol (ethanol) – pure	CH_3CH_2OH	O	+	O	+	+
Ethyl alcohol + acetic acid	$CH_3CH_2OH + CH_3COOH$	O	+	O	+	+
Ethyl alcohol – fermented mash		+	+	+	+	+
Ethyl alcohol – methylated (spirit)		O	O	O	+	+
Ethylbenzene – pure	$C_6H_5CH_2CH_3$	-	-	O	+	+
Ethyl chloride – pure	CH_3CH_2Cl	+	+	+	+	+
Ethylene – pure	$CH_2=CH_2$	+	-	+	+	+
Ethylene bromide (anhydrous) – pure	$CH_2=CHBr$	-	-	-	+	+
"Ethylene chlorohydrin (chloroethanol) – pure"	$ClCH_2CH_2OH$	-	-	O	+	+
"Ethylene chloride (dichloroethane) – pure"	$ClCH_2CH_2Cl$	-	-	-	+	-
Ethylenediamine – pure	$NH_2CH_2CH_2NH_2$	O	+	O	+	O
Ethylene glycol (glycol) – pure	$HOCH_2CH_2OH$	+	+	+	+	+
Ethylene oxide – pure	CH_2CH_2O	-	-	-	+	+
Ethyl formate – pure	$HCOOCH_2CH_3$	-	O	-	+	+
"Exhaust fumes – containing hydrogen fluoride"		+	+	+	O	O
Exhaust fumes – containing carbon dioxide		+	+	+	+	O
Exhaust fumes – containing carbon monoxide		+	+	+	+	+
Exhaust fumes – containing nitrous gases		O	+	+	+	+

Interpretation of Symbols + material is not affected or is slightly affected by the chemical: suitable O various attack level depending on prevailing conditions: limited suitability - material exhibits severe attack: unsuitable	FORMULA					
		NBR	EPDM	FPM	AIISI 316L	AIISI 304
CHEMICALS						
Exhaust fumes – containing hydrochloric acid		+	+	+	O	-
Exhaust fumes – containing sulphur dioxide (dry)		O	+	+	+	+
Exhaust fumes – containing sulphuric acid (humid)		O	+	+	+	O
Exhaust fumes – containing sulphur trioxide (dry)		O	+	+	+	+
F						
Fatty alcohols		+	O	+	+	O
Fatty alcohol sulphates – aqueous		+	O	+	+	+
Ferric chloride – aqueous (saturated)	$FeCl_3$	+	+	+	-	-
Fluorine (dry) – pure	F_2	-	-	O	+	+
Fluorine (humid) – pure	F_2	-	-	-	O	O
"Fluoroboric acid (boron hydrofluoric acid)"	HF_3	+	+	+	-	-
Fluosilicic acid – aqueous	H_2SiF_6	O	O	O	O	O
"Formaldehyde solution (formalin) – aqueous"	CH_2O	O	O	O	+	+
Formamide – pure	$HCONH_2$	+	+	O	+	O
Formic acid – pure	$HCOOH$	-	O	-	+	O
Formic acid – aqueous	$HCOOH$	-	O	O	+	O
Frigene 12 (R-12) – pure	CCl_2F_2	+	-	O	+	+
Frigene 13 (R-13) – pure	$CClF_3$	+	-	O	+	+
"Frigene 13 B 1 (R-13B1; halon 1301) – pure"	CBF_3	+	-	O	+	+
Frigene 22 (R-22) – pure	$CHClF_2$	-	-	-	+	+
Frigene 23 (R-23) – pure	CHF_3	+	-	O	+	+
Frigene 113 (R-113) – pure	Cl_2FCClF_2	+	-	-	+	+
Frigene 502 (R-502) – pure	$C_2F_5Cl + CHF_2Cl$	-	-	-	+	+
"Frigene substitute HFCKW 123 (R-123) – pure"	F_3CCHCl_2	-	-	-	+	+
"Frigene substitute HFCKW 134a (R-134a) – pure"	F_3CCH_2F	-	+	+	+	+
Fuming sulphuric acid (Oleum) – pure	H_2SO_4	-	-	O	+	O
G						
Glycerine – aqueous	$HOCH_2CH(OH) - CH_2OH$	+	+	+	+	O
Glycerine – pure	$HOCH_2CH(OH) - CH_2OH$	O	+	+	+	O
Glycine (aminoacetic acid) – aqueous	NH_2CH_2COOH	O	+	+	+	+
Glycol (ethylene glycol) – pure	$HOCH_2CH_2OH$	+	+	+	+	+
Glycol ethyl ether (cellosolve) – pure	$HO(CH_2)_2OCH_2CH_3$	-	-	-	+	+
Glycolic acid – aqueous	$HOCH_2COOH$	+	+	+	O	O
Glycose (dextrose) – aqueous	$C_6H_{12}O_6$	+	+	+	+	+
Grid gas (illuminating gas, town gas)	+	+	+	+	+	+
H						
Helium – pure	He	+	+	+	+	+
Heptane (hexane, benzene) – pure		+	-	+	+	+
"Hexamethylene tetramine (Urotropin) – aqueous"	$C_6H_{12}N_4$	+	+	+	+	+
Humic acids		+	+	+	+	+
Hydrazine hydrate – aqueous	$NH_2NH_2 \times x H_2O$	-	+	+	-	O
Hydrobromic acid – aqueous	HBr	-	+	+	-	-
Hydrochloric acid – aqueous (36%)	HCl	-	O	+	O	O
Hydrocyanic acid – aqueous	HCN	O	O	+	+	O
Hydrofluoric acid – aqueous	HF	-	-	-	O	-
Hydrogen chloride gas – pure	HCl	O	+	+	+	O
Hydrogen peroxide 0.5%	H_2O_2	O	+	+	+	O
Hydrogen peroxide 30%	H_2O_2	-	O	+	O	-
Hydrogen – pure	H_2	+	+	+	+	+
Hydrogen sulphide – aqueous	H_2S	O	+	-	+	+
Hydroquinone – aqueous	$C_6H_4(OH)_2$	+	+	+	+	+
"Hydroxybenzene (carbolic acid, phenol) – aqueous"	C_6H_5OH	O	O	O	+	+
Hydroxylamine sulphate – aqueous	$(NH_2OH)_2SO_4$	+	+	+	+	+
I						
Illuminating gas (town gas, grid gas)		+	+	+	+	+
Inert gases – pure		+	+	+	O	+
Iodine + potassium iodine – aqueous	$I_2 + KI$	O	O	O	O	O
Iron sulphate – aqueous	$FeSO_4$	+	+	+	+	+
Isobutanol – pure	$(CH_3)_2CHCH_2OH$	O	+	+	+	+
Isocetane – pure	$CH_3(CH_2)_7CH_2CH(CH_3)_2$	+	-	+	+	+
Isopropanol (2-propanol) – pure	$CH_3CH(OH)CH_3$	O	+	+	+	+

CHEMICAL RESISTANCE TABLE

Interpretation of Symbols + material is not affected or is slightly affected by the chemical: suitable O various attack level depending on prevailing conditions: limited suitability - material exhibits severe attack: unsuitable	FORMULA	NBR	EPDM	FPM	AISI 316L	AISI 304
CHEMICALS						
K						
Kerosene		+	-	+	+	+
L						
Lactic acid – aqueous	HOOCCH(OH)CH ₃	O	O	+	O	O
Laughing gas (dinitrogen monoxide, nitrous oxide) – pure	N ₂ O	+	+	+	+	+
Lead acetate – aqueous	Pb(CH ₃ COO) ₂	O	+	+	+	+
Lead nitrate – aqueous	Pb(NO ₃) ₂	+	+	+	+	+
Lead tetraethyl (tetraethyl lead) – pure	Pb(CH ₂ CH ₃) ₄	O	O	+	+	+
Light petroleum (petroleum spirit)		+	-	+	+	+
"Lime water (calcium hydroxide) – aqueous"	Ca(OH) ₂	+	+	+	+	+
Linoleic acid – pure	C ₁₈ H ₃₂ O	O	-	O	+	O
Lithium chloride – aqueous	LiCl	+	+	+	O	O
M						
Magnesium chloride – aqueous	MgCl ₂	+	+	+	O	O
Magnesium sulphate – aqueous	MgSO ₄	+	+	+	+	+
Maleic acid – aqueous	HOOCCH=CHCOOH	+	+	+	+	O
Malic acid – aqueous	HOOCCH ₂ CHOH-COOH	+	+	+	+	+
Manganese chloride – aqueous	MnCl ₂	+	+	+	O	O
Manganese sulphate – aqueous	MnSO ₄	+	+	+	+	+
Marsh gas (methane, mine gas)	CH ₄	+	-	+	+	+
Mercaptane		-	-	O	+	+
Mercury – pure	Hg	+	+	+	O	+
Mercury chloride – aqueous	HgCl ₂	+	+	+	O	O
Mercury salts – aqueous		+	+	+	+	+
Methane (mine gas, marsh gas)	CH ₄	+	-	+	+	+
Methanol (methyl alcohol) – pure	CH ₃ OH	-	+	-	+	O
Methoxybenzene (Anisole) – pure	C ₆ H ₅ OCH ₃	O	O	-	+	+
Methoxybutanol – pure	CH ₃ O(CH ₂) ₃ CH ₂ OH	+	+	+	+	+
Methoxybutyl acetate (butoxyl) – pure	CH ₃ OC(H ₂) ₃ CCH ₃	+	O	O	+	+
Methyl acetate – pure	CH ₃ COOCH ₃	-	O	-	O	O
Methyl alcohol (methanol) – pure	CH ₃ OH	-	+	-	+	O
Methylamine – aqueous	CH ₃ NH ₂	-	O	O	O	O
Methyl chloride (chloromethane) – pure	CH ₃ Cl	-	-	+	+	+
"Methylene chloride (dichloromethane) – pure"	CH ₂ Cl ₂	-	-	O	+	+
Methyl ethyl ketone (2-butanone) – pure	CH ₃ COCH ₂ CH ₃	-	O	-	+	+
Mine gas (methane, marsh gas)	CH ₄	+	-	+	+	+
Monosodium glutamate – aqueous	C ₆ H ₉ NNaO ₄	+	+	+	+	+
Morpholine – pure	C ₄ H ₉ NO	-	O	O	+	+
N						
Natural gas		+	-	+	+	+
Nickel sulphate – aqueous	NiSO ₄	+	+	+	O	O
Nitrogen oxides (nitrous fumes)	"(NO, NO ₂ , N ₂ O ₃ , N ₂ O ₄ , etc.)"	-	O	-	O	-
Nitrogen – pure	N ₂	+	+	+	+	+
Nitrous oxide (laughing gas, dinitrogen monoxide) – pure	N ₂ O	+	+	+	+	+
Nitric acid – aqueous (40%)	HNO ₃	-	-	+	+	-
Nitrobenzene – pure	C ₆ H ₅ NO ₂	-	-	O	+	+
Nitrobenzoic acids – aqueous	C ₆ H ₄ NO ₂	+	+	+	+	+
Nitrous fumes (nitrogen oxides)	"(NO, NO ₂ , N ₂ O ₃ , N ₂ O ₄ , etc.)"	-	O	-	O	-
Nitrotoluenes (o-, m-, p-) – pure	C ₆ H ₄ (NO ₂)(CH ₃)	O	-	O	+	+
O						
Oleum (fuming sulphuric acid) – pure	H ₂ SO ₄	-	-	O	+	O
Oxygen – pure	O ₂	O	O	+	+	+
Ozone (humid and dry)	O ₃	-	O	O	+	+
P						
Paraffin oil		+	-	+	+	+
Peracetic acid – aqueous (6%)	CH ₃ CO ₂ H	-	O	-	+	+
"Perchloroethylene (tetrachloroethylene) – pure"	Cl ₂ CCl ₂	-	-	O	+	+
Peroxo monosulphuric acid – aqueous	H ₂ SO ₅	-	-	-	-	-
Petroleum spirit (light petroleum)		+	-	+	+	+

Interpretation of Symbols + material is not affected or is slightly affected by the chemical: suitable O various attack level depending on prevailing conditions: limited suitability - material exhibits severe attack: unsuitable	FORMULA	NBR	EPDM	FPM	AISI 316L	AISI 304
CHEMICALS						
"Phenol (hydroxybenzene, carbolic acid) – aqueous"	C ₆ H ₅ OH	O	O	O	+	+
Phosgene (carbonyl chloride) [liquid] – pure	COCl ₂	-	O	+	+	+
"Phosgene (carbonyl chloride) [gaseous] – pure"	COCl ₂	-	+	+	+	+
Phosphoric acid – aqueous	H ₃ PO ₄	O	O	+	+	-
Phosphorus chlorides – pure	PCl ₃ , PCl ₅ , PCl ₅	-	-	O	O	O
Picric acid (trinitrophenol) – pure	C ₆ H ₃ (OH)(NO ₂) ₃	O	-	O	+	+
Pinene (turpentine oil) – pure	O	-	O	+	+	+
"Potash (potassium carbonate) – aqueous"	K ₂ CO ₃	+	+	+	+	+
"Potassium aluminium sulphate (alum) – aqueous"	KAl(SO ₄) ₂ x 12 H ₂ O	+	+	+	+	O
Potassium bromate – aqueous	KBrO ₃	+	+	+	+	O
Potassium bromide – aqueous	KBr	+	+	+	O	O
"Potassium carbonate (potash) – aqueous"	K ₂ CO ₃	+	+	+	+	+
Potassium chlorate – aqueous	KClO ₃	O	O	O	O	O
Potassium chloride – aqueous	KCl	+	+	+	O	O
Potassium chromate – aqueous	K ₂ CrO ₄	O	+	O	O	O
Potassium cyanide – aqueous	KCN	+	+	+	+	+
Potassium dichromate – aqueous	K ₂ Cr ₂ O ₇	O	O	O	+	+
Potassium ferrocyanide (II) (yellow prussiate of potash) – aqueous	K ₄ [Fe(CN) ₆]	+	+	+	O	-
Potassium ferrocyanide (III) (red prussiate of potash) – aqueous	K ₃ [Fe(CN) ₆]	+	+	+	+	+
Potassium hydrogen fluoride – aqueous	KHF ₂	+	+	+	+	+
Potassium hydroxide (caustic potash) – aqueous	KOH	-	+	-	+	+
Potassium hypochlorite – aqueous	KOCl	-	+	O	O	O
Potassium iodide – aqueous	KI	+	+	+	O	O
Potassium nitrate – aqueous	KNO ₃	+	+	+	O	O
Potassium nitrite – aqueous	KNO ₂	+	+	+	+	+
Potassium permanganate – aqueous	KMnO ₄	-	-	-	+	O
Potassium peroxide – aqueous	K ₂ O ₂	-	-	-	+	+
Potassium persulphate – aqueous	K ₂ S ₂ O ₈	-	+	O	+	+
Potassium phosphate – aqueous	K ₃ PO ₄	+	+	+	+	+
Potassium sulphate – aqueous	K ₂ SO ₄	+	+	+	+	+
Potassium sulphide – aqueous	K ₂ S	+	+	+	+	+
Potassium sulphite – aqueous	K ₂ SO ₃	+	+	+	+	O
Propane (liquid and gaseous) – pure	C ₃ H ₈	+	-	+	+	+
Propanol – pure	CH ₃ CH ₂ CH ₂ OH	+	+	+	+	+
Propylene glycol – pure	HOCH ₂ CH ₂ CH ₂ OH	+	+	+	+	+
Protein solutions		+	+	+	+	+
Pyridine – pure	C ₅ H ₅ N	-	-	-	+	O
R						
"Red prussiate of potash (Potassium ferrocyanide (III)) – aqueous"	K ₃ [Fe(CN) ₆]	+	+	+	+	+
S						
Shellsol D (turpentine substitute, white spirit) – pure		O	-	O	+	+
Silicone oil		+	+	+	+	+
Silver nitrate – aqueous	AgNO ₃	O	+	+	+	+
Soda lye (sodium hydroxide) – aqueous	NaOH	O	+	O	O	O
Sodium arsenate – aqueous	Na ₂ AsO ₄	+	+	+	+	+
Sodium arsenite – aqueous	Na ₂ AsO ₃	+	+	+	+	+
Sodium benzoate – aqueous"	C ₆ H ₅ COONa	+	+	+	+	+
Sodium bicarbonate (sodium hydrogen carbonate) – aqueous	NaHCO ₃	+	+	+	+	+
Sodium bisulphate (sodium hydrogen sulphate) – aqueous	NaHSO ₄	+	+	+	O	O
Sodium bisulphite (bisulphite, sodium hydrogen sulphide) – aqueous	NaHSO ₃	O	+	+	+	O
Sodium bromate – aqueous	NaBrO ₃	+	+	+	+	+
Sodium bromide – aqueous	NaBr	+	+	+	O	O
Sodium carbonate (soda) – aqueous	Na ₂ CO ₃	+	+	+	+	+
Sodium chlorate – aqueous	NaClO ₃	O	O	O	O	O
Sodium chloride (table salt) – aqueous	NaCl	+	+	+	O	O
Sodium chlorite – aqueous	NaClO ₂	-	O	O	O	-
Sodium chloroacetate – aqueous	NaCH ₂ ClCOO	+	+	+	+	+
Sodium chromate – aqueous	NaCrO ₄	O	+	O	O	O
Sodium cyanide – aqueous	NaCN	+	+	+	+	+



A WATTS Brand

CHEMICAL RESISTANCE TABLE

Interpretation of Symbols + material is not affected or is slightly affected by the chemical: suitable O various attack level depending on prevailing conditions: limited suitability - material exhibits severe attack: unsuitable	FORMULA					
		NBR	EPDM	FPM	AISI 316L	AISI 304
CHEMICALS						
Sodium disulphite (sodium metabisulphite) – aqueous	Na ₂ S ₂ O ₅	O	+	+	+	O
Sodium dodecylbenzenesulfonate – aqueous	C ₁₈ H ₂₉ NaO ₃ S	+	+	+	+	+
Sodium fluoride – aqueous	NaF	+	+	+	+	O
Sodium hydrogen carbonate (sodium bicarbonate) – aqueous	NaHCO ₃	+	+	+	+	+
Sodium hydrogen sulphate (sodium bisulphate) – aqueous	NaHSO ₄	+	+	+	O	O
Sodium hydrogen sulphide (sodium bisulphite, bisulphite) – aqueous	NaHSO ₃	O	+	+	+	O
Sodium hydroxide (soda lye) – aqueous	NaOH	O	+	O	O	O
Sodium hypochlorite (chlorine bleaching lye) – aqueous	NaOCl	-	O	O	O	O
Sodium iodide – aqueous	NaI	+	+	+	O	O
Sodium mercaptobenzothiazole – pure	C ₇ H ₅ NS ₂	O	O	+	+	+
Sodium metabisulphite (sodium disulphite) – aqueous	Na ₂ S ₂ O ₅	O	+	+	+	O
Sodium nitrate – aqueous	NaNO ₃	+	+	+	+	-
Sodium nitrite – aqueous	NaNO ₂	+	+	+	+	+
Sodium pentachlorophenolate – aqueous	C ₆ Cl ₅ NaO	+	+	+	+	+
Sodium perborate – aqueous	NaBO ₃ · xNH ₃ O	O	+	+	+	+
Sodium peroxodisulphate – aqueous	Na ₂ S ₂ O ₈	O	+	+	+	O
Sodium phosphate – aqueous	Na ₃ PO ₄	+	+	+	O	O
Sodium propionate – aqueous	CH ₃ CH ₂ COONa	+	+	+	+	+
Sodium silicate (soluble glass) – aqueous		+	+	+	+	+
Sodium stannate – aqueous	Na ₂ SnO ₃	+	+	+	+	+
Sodium sulphate – aqueous	Na ₂ SO ₄	+	+	+	+	+
Sodium sulphide – aqueous	Na ₂ S	+	+	+	+	+
Sodium sulphite – aqueous	Na ₂ SO ₃	+	+	+	+	O
Sodium tartrate – aqueous	C ₄ H ₄ O ₆ Na ₂	+	+	+	+	+
Sodium thiosulphate – aqueous	Na ₂ S ₂ O ₃	+	+	+	O	O
Sodium zincate – aqueous	Na ₂ [Zn(OH) ₄]	O	+	+	+	+
Spirit (ethyl alcohol)		O	O	O	+	+
Starch solution – aqueous		+	+	+	+	+
Stearic acid – pure	C ₁₈ H ₃₅ COOH	+	+	+	+	+
Styrene – pure	C ₆ H ₅ CH=CH ₂	-	-	O	+	+
Succinic acid – aqueous	HOOCCH ₂ CH ₂ COOH	+	+	+	+	+
Sulphur chloride – pure	S ₂ Cl ₂ , SCl ₂ , SCl ₄	-	-	+	+	-
Sulphur dioxide (liquid) – pure	SO ₂	-	+	+	+	+
Sulphur dioxide (gaseous and humid)	SO ₂	-	+	+	+	O
Sulphur dioxide (gaseous and dry) – pure	SO ₂	-	+	+	+	O
Sulphur hexafluoride – pure	SF ₆	O	+	O	+	+
Sulphuric acid – concentrated (96%)	H ₂ SO ₄	-	-	O	-	-
Sulphuric acid – aqueous (30%)	H ₂ SO ₄	O	+	+	-	-
Sulphurous acid – aqueous	H ₂ SO ₃	O	+	+	+	-

Interpretation of Symbols + material is not affected or is slightly affected by the chemical: suitable O various attack level depending on prevailing conditions: limited suitability - material exhibits severe attack: unsuitable	FORMULA					
		NBR	EPDM	FPM	AISI 316L	AISI 304
CHEMICALS						
T						
Table salt (sodium chloride) – aqueous	NaCl	+	+	+	O	O
Tall oil (colophonium) (liquid)		O	O	O	+	O
Tannic acid (tannin) – aqueous		+	+	+	+	+
Tartaric acid – aqueous	C ₄ H ₆ O ₆	+	+	+	+	+
Tetrachloroethylene (perchloroethylene) – pure	Cl ₂ CCCl ₂	-	-	O	+	+
Tetraethyl lead (lead tetraethyl) – pure	Pb(CH ₂ CH ₃) ₄	O	O	+	+	+
Tetrahydrofuran – pure	C ₄ H ₈ O	-	-	-	+	+
Tetrahydronaphthalene (tetralin) – pure	C ₁₀ H ₁₂	-	-	+	+	+
Thiophene – pure	C ₄ H ₄ S	-	-	-	+	+
Tin chlorides – aqueous	SnCl ₂ , SnCl ₄	+	+	+	O	-
Toluene – pure	C ₆ H ₅ CH ₃	-	-	O	+	+
Town gas (grid gas, illuminating gas)		+	+	+	+	+
Tributyl phosphate – pure	(C ₄ H ₉ O) ₃ PO	-	-	-	+	+
Trichloroacetic acid – aqueous	Cl ₃ CCOOH	O	O	-	-	-
Trichloroethylene – pure	C ₂ HCl ₃	-	-	O	+	+
Trichloromethane (chloroform) – pure	CHCl ₃	-	-	O	+	+
Tricresylphosphate – pure	C ₂₁ H ₃₃ O ₆ P	-	-	-	+	+
Triethanolamine – pure	(CH ₂ CH ₂ OH) ₃ N	-	-	-	+	+
Trinitrophenol (picric acid) – pure	C ₆ H ₂ (OH)(NO ₂) ₃	O	-	O	+	+
U						
Uranium hexafluoride – pure	UF ₆	+	+	+	+	O
Urea – aqueous	NH ₂ CONH ₂	+	+	+	O	O
Urotropin (hexamethylene tetramine) – aqueous	C ₆ H ₁₂ N ₄	+	+	+	+	+
V						
Vinyl acetate – pure	CH ₃ CH=OCH ₂ CH ₃	+	+	+	+	+
Vinyl chloride – pure	CH ₂ CHCl	-	O	+	O	O
W						
Water – distilled	H ₂ O	+	+	+	+	O
Water (seawater)	H ₂ O	+	+	+	O	O
Water vapour (130 °C)	H ₂ O	O	+	+	+	+
White spirit (Shellsol D, turpentine substitute) – pure	O	-	O	+	+	
Wood tar (impregnating oils)	-	-	-	+	+	
X						
Xenon – pure	Xe	+	+	+	+	+
Xylene – pure	C ₆ H ₄ (CH ₃) ₂	-	-	O	+	+
Y						
Yeast – aqueous	+	+	+	+	+	
Yellow prussiate of potash (Potassium ferrocyanide (II)) – aqueous	K ₄ [Fe(CN) ₆]	+	+	+	O	-
Z						
Zinc chloride – aqueous	ZnCl ₂	+	+	+	O	-
Zinc sulphate – aqueous	ZnSO ₄	+	+	+	+	-

CHEMICAL RESISTANCE TABLE

Interpretation of Symbols + material is not affected or is slightly affected by the chemical: suitable O various attack level depending on prevailing conditions: limited suitability - material exhibits severe attack: unsuitable	FORMULA	NBR	EPDM	FPM	AISI 316L	AISI 304
COMMERCIAL PRODUCTS						
A						
	Acronal dispersions (polyacrylates)	-	+	+	+	+
	Acronal solutions	-	O	-	+	+
	Alkane sulfonic acid chlorides (mersoles)	+	O	+	O	O
	Anise oil	O	+	+		
	Antifrogen-N	+	+	+	+	+
	ASTM fuel A	O	-	O	+	+
	ASTM fuel B	O	-	O	+	+
	ASTM fuel C	O	-	O	+	+
	ASTM oil IRM 901	+	-	+	+	+
	ASTM oil IRM 902	O	-	+	+	+
	ASTM oil IRM 903	O	-	O	+	+
	ATE brake fluid (brake fluid)	-	+	-	+	+
B						
	Beeswax	+	+	+	+	+
	Biodiesel (fatty acid methyl ester)	O	-	+	+	+
	Bone oil	O	-	+	+	+
	Brake fluid (ATE brake fluids)	-	+	-	+	+
C						
	Car antifreeze	O	+	+		
	Cellulose lacquers	-	O	-	+	+
	Chlophene (chlorodiphenyl)	+	O	+	+	+
	Coconut oil	O	-	O	+	+
	Cotton seed oil	O	-	+	+	+
	Cutting oil (drilling oil)	O	-	O	+	+
	Cyclanone (fatty alcohol sulfonate)	+	+	+	+	+
D						
	Desmodur T	-	-	+	+	+
	Desmophen	+	+	+	+	+
	Detergent (synth. laundry detergent)	O	+	O	+	+
	Dextrin – aqueous	+	+	+	+	+
	Diesel oil – pure	O	-	+	+	+
	Drilling oil (cutting oil)	O	-	O	+	+
	Dyeworks wetting agent (Nekal BX)	+	+	+	+	+
E						
	Engine oils (machine oils, paraffin oils, mineral oils)	+	-	+	+	+
F						
	Fatty acid methyl ester (biodiesel)	O	-	+	+	+
	Fatty alcohol sulfonate (cyclanone)	+	+	+	+	+
	Fatty oils (greases)	O	-	O	+	+
	Fish liver oil	O	O	+	+	+
	Fruit tree carbolineum	O	O	O	+	+
	Fuel oils	O	-	+	+	+
G						
	Gelatine – aqueous	+	+	+	+	+
	Greases (fatty oils)	O	-	O	+	+
H						
	Hair shampoo	O	O	O	+	+
	Hydraulic fluid (Skydrol 500)	-	+	O	+	+
	Hydraulic fluid (Skydrol 7000)	-	+	-	+	+
	Hydraulic fluids – chlorinated hydrocarbons	-	O	+	+	+
	Hydraulic fluids – mineral oil based (H, H-L, H-LP)	O	-	O	+	+
	Hydraulic fluids – phosphoric acid ester (HSD)	-	O	-	+	+
	Hydraulic fluid – polyglykol water (HSC)	+	+	+	+	+
	Hydraulic fluids – water in oil (HSB)	O	-	+	+	+
	Hydraulic fluids – water-oil emulsions (HSA)	O	-	+	+	+

Interpretation of Symbols + material is not affected or is slightly affected by the chemical: suitable O various attack level depending on prevailing conditions: limited suitability - material exhibits severe attack: unsuitable	FORMULA	NBR	EPDM	FPM	AISI 316L	AISI 304
COMMERCIAL PRODUCTS						
I						
	Impregnating oils (wood tar)	-	-	-	+	+
	Iodine tincture	O	O	O	O	O
L						
	Linseed oil	O	-	O	+	+
	Lubricating oils	+	-	+	+	+
	Lysol	-	-	O	+	O
M						
	Machine oils (paraffin oils, mineral oils, engine oils)	+	-	+	+	+
	Mersoles (alkane sulfonic acid chlorides)	+	O	+	O	O
	Mineral oils (paraffin oils, machine oils, engine oils)	+	-	+	+	+
	Molasses (molasses-based flavour)	+	+	+	+	+
N						
	Nekal BX (dyeworks wetting agent) – aqueous	+	+	+	+	+
	Nickel baths	+	+	+	+	O
P						
	Paraffin oils (machine oils, mineral oils, engine oils)	+	-	+	+	+
	Petroleum – pure	+	-	+	+	+
	Petroleum benzole spirit (premium grade petrol-ethanol mixture)	-	-	O	+	+
	Photograph emulsions, developers, fixing baths	O	O	O		
	Pine needle oil (spruce needle oil)	O	-	+	+	+
	Polyacrylates (acronal dispersions)	-	+	+	+	+
	Premium grade petrol-ethanol mixture (petroleum benzole spirit)	-	-	O	+	+
S						
	Skydrol 500 (hydraulic fluid)	-	+	O	+	+
	Skydrol 7000 (hydraulic fluid)	-	+	-	+	+
	Soap solution – aqueous	O	O	O	+	+
	Soda (sodium carbonate) – aqueous	+	+	+	+	+
	Soluble glass (sodium silicates)	+	+	+	+	+
	Spindle oils	+	+	+	+	+
	Spruce needle oil	O	-	+	+	+
	Synth. Laundry detergent (detergent)	O	+	O	+	+
T						
	Table salt (sodium chloride)	+	+	+	O	O
	Transformer oil	+	-	+	+	+
	Turpentine oil (pinene) – pure	O	-	O	+	+
	Turpentine substitute (white spirit, Shellsol D) – pure	O	-	O	+	+
U						
	UV paint	-	+	-		
V						
	Varnishes	O	-	+	+	+
	Vinegar 5% (grape vinegar)	-	+	O	O	+

CHEMICAL RESISTANCE TABLE

Interpretation of Symbols + material is not affected or is slightly affected by the chemical: suitable O various attack level depending on prevailing conditions: limited suitability - material exhibits severe attack: unsuitable	FORMULA	NBR	EPDM	FPM	AISI 316L	AISI 304
A						
	Apple juice (apple sauce)	+	+	+	+	+
	Apricot juice	+	+	-	+	+
			O	+	O	O
B						
	Beer	+	+	+	+	+
	Butter	+	+	+	+	+
	Buttermilk	+	+	+	+	+
C						
	Cider	+	+	+	+	+
	Corn oil	O	-	O	+	+
E						
	Edible oil	O	-	O	+	+
F						
	Fruit juices	O	O	O	+	+
	Food fats and oils	O	-	O	+	+
G						
	Grape vinegar (vinegar 5%)	-	+	O	O	+
L						
	Lemon juice	O	+	+	+	O

Interpretation of Symbols + material is not affected or is slightly affected by the chemical: suitable O various attack level depending on prevailing conditions: limited suitability - material exhibits severe attack: unsuitable	FORMULA	NBR	EPDM	FPM	AISI 316L	AISI 304
M						
	Milk		+	+	+	+
	Mineral water		+	+	+	O
O						
	Olive oil		O	-	O	+
	Orange juice		+	+	+	O
P						
	Pineapple juice		+	+	+	O
R						
	Rape seed oil		O	-	O	+
S						
	Saccharine (sweetener)		+	+	+	+
	Soybean oil		O	-	O	+
	Spirits (dependent on their ingredients)		O	O	O	+
	Sugar solutions		+	+	+	+
	Sweetener (saccharine)		+	+	+	+
W						
	Wines		+	+	+	+

Joint Fixing & Pressure Ratings

Precautions should be taken to ensure BLÜCHER push-fit joints do not separate during testing or actual use. Uncaptured joints must be secured to the building, or secured with Joint Clamps (fig. 1).

Dimpling Tool to increase the pressure rating of the system (fig. 2). Consult BLÜCHER Technical for applications with anticipated pressures beyond those listed below.

Projections can be added to the spigot end of the pipe with a Pipe

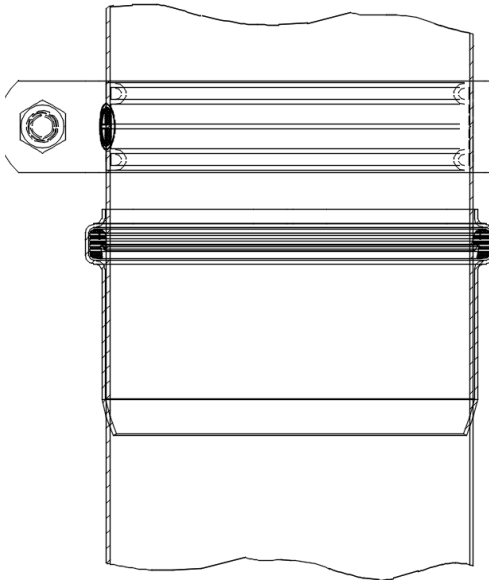

Fig. 1. Pipe Hanger

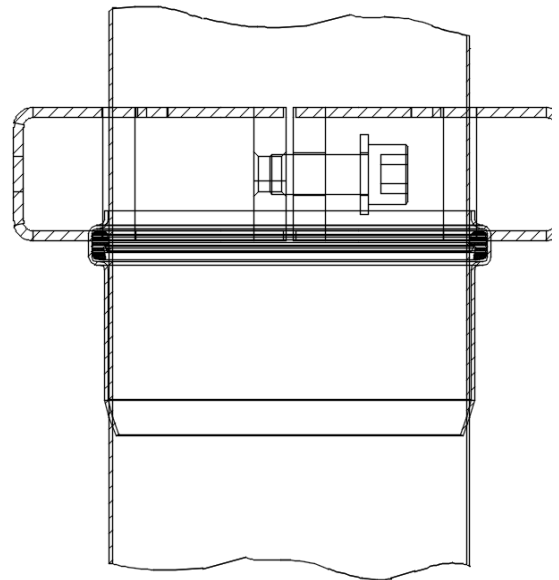

Fig. 2. Peak Pressure Clamp

Secured with	Pipe Hangers Only		Blucher Pipe Clamps			Blucher Peak Pressure Pipe Clamps	
Blucher Product Series #			Series #847.050.XXX(Global) or JC (North America)			Series #847.001.XXX	
Additional Steps			With Clamp	With Clamp and Projections			
Pipe Size inch (mm)	Vacuum Rating psi (bar)	Pressure ¹ Rating psi (bar)	Pressure ¹ Rating psi (bar)	Pressure ¹ Rating psi (bar)	# Of Projections Required	Pressure ¹ Rating psi (bar)	Peak ² Pressure Rating Psi (bar)
1/2" (40)	12 (-0.85)	7 (0.5)	29 (2.0)	44 (3.0)	n/a	44 (3.0)	145 (10.0)
2" (50)	12 (-0.85)	7 (0.5)	29 (2.0)	44 (3.0)	2	44 (3.0)	145 (10.0)
3" (76)	12 (-0.85)	7 (0.5)	29 (2.0)	44 (3.0)	6	44 (3.0)	145 (10.0)
4" (110)	-9 (-0.6)	7 (0.5)	29 (2.0)	44 (3.0)	8	44 (3.0)	109 (7.5)
6" (160)	-9 (-0.6)	7 (0.5)	15 (1.0)	44 (3.0)	16	44 (3.0)	73 (5.0)
8 (203)	9 (-0.6)	3 (0.2)	7 (0.5)	36 (2.5)	16	36 (2.5)	58 (4.0)
10" (250)	9 (0.6)	n/a	3 (0.2)	29 (2.0)	16	29 (2.0)	44 (3.0)
12"(315)	n/a	n/a	n/a	n/a	n/a	15 (1.0)	22 (1.5)

Notes:

1. Maximum pressure allowed for system blockages.
2. Maximum pressure allowed for a brief instance of increased usage, such as the beginning of a water buildup. This rating is defined as 60% of the pressure which first causes the clamp to move, provided it can also pass 50 load cycles followed by a 15 minute static test at this maximum pressure.

Pipe cutting and jointing

Cutting

BLÜCHER manual or electric pipe cutters should be used for projects requiring a significant amount of cutting. Pipe cut with a BLÜCHER cutter can be installed without subsequent finishing.

For small requirements, BLÜCHER pipe can be cut with a standard pipe cutter, equipped with a cutting wheel or blade for stainless steel. All cuts should be deburred, and filed to create a slight bevel for insertion into the gasketed socket.

Jointing

Prior to assembly, make sure both pipe ends are clean, and the gasket is properly positioned in the socket. Spray on small amount of BLÜCHER Jointing Lubricant on the gasket side. With a slight twisting movement, push the pipes together.

Manual pipe cutter

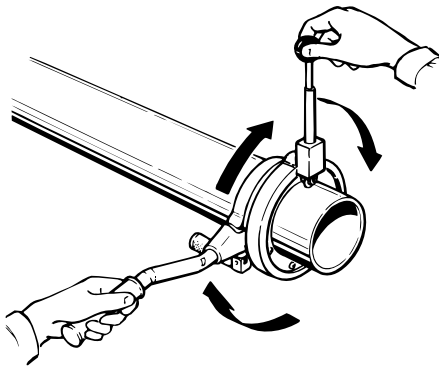

Electric pipe cutter



Jointing of socket and spigot end

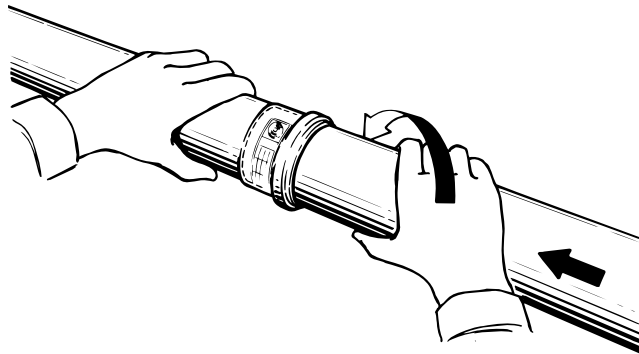
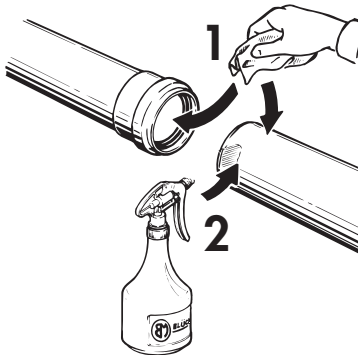

Insertion depth

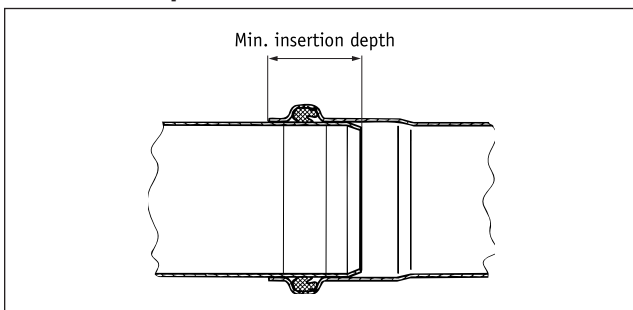

Pipe Size	Max. Insertion Depth	Min. Insertion Depth
1.5"(40)	1-7/8"(47)	1-3/16"(30)
2"(50)	1-7/8"(47)	1-3/16"(30)
3"(75)	2-3/16"(55)	1-3/8"(35)
4"(110)	2-7/16"(62)	1-9/16"(40)
6"(160)	3"(76)	2"(50)
8"(200)	3-7/8"(98)	2-1/2"(63)
10"(250)	4-9/16"(116)	2-3/4"(70)

Stainless Steel Pipe

Pipe Dimensions

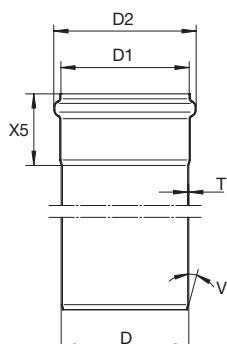

Dimensional Chart

<i>Pipe Size</i> D	D1	D2	X5	T	V
1.5"(40)	5/8"(41)	2"(52)	5/8"(41)	18 ga.(1.25)	20 deg.
2"(50)	2-1/16"(51)	2-3/8"(61)	1-7/8"(47)	20 ga.(1)	20 deg.
3"(75)	3"(76)	3-7/16"(87)	2-3/16"(55)	20 ga.(1)	20 deg.
4"(110)	4-3/8"(111)	4-13/16"(123)	2-7/16"(62)	20 ga.(1)	20 deg.
6"(160)	6-5/16"(161)	7"(177)	3-1/16"(78)	18 ga.(1.25)	20 deg.
8"(200)	7-15/16"(201)	8-5/8"(219)	3-7/8"(98)	16 ga.(1.5)	20 deg.
10"(250)	9-7/8"(251)	10-15/16"(277)	4-5/8"(116)	16 ga.(1.5)	20 deg.

Straight Pipe with One Socket

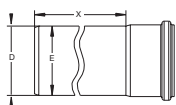
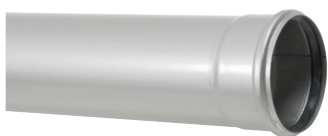

Bends

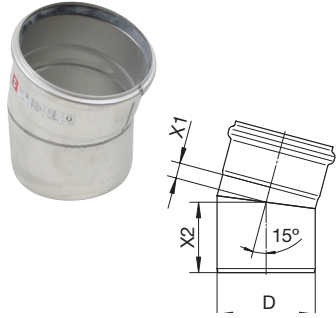

15° Bend Dimensional Chart

Model No.	Global Part #	D	X1	X2
B1.5-15-316	820.015.040S	1.5"(40)	5/8"(15)	2-1/16"(53)
B2-15-316	820.015.050S	2"(50)	5/16"(7)	2-3/16"(54)
B3-15-316	820.015.075S	3"(75)	7/16"(11)	2-5/8"(66)
B4-15-316	820.015.110S	4"(110)	11/16"(16)	3-1/8"(78)
B6-15-316	820.015.160S	6"(160)	15/16"(23)	3-15/16"(99)
B8-15-316	820.015.200S	8"(200)	15/16"(23)	4-7/8"(123)
B10-15-316	820.015.250S	10"(250)	1-3/16"(30)	5-3/8"(136)

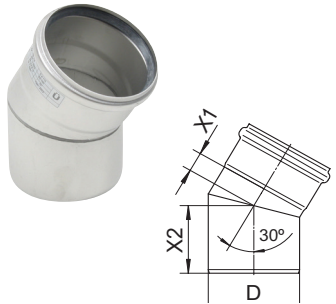

30° Bend Dimensional Chart

Model No.	Global Part #	D	X1	X2
B1.5-30-316	820.030.040S	1.5"(40)	11/16"(18)	2-3/16"(55)
B2-30-316	820.030.050S	2"(50)	7/16"(11)	2-1/4"(57)
B3-30-316	820.030.075S	3"(75)	11/16"(16)	2-13/16"(71)
B4-30-316	820.030.110S	4"(110)	15/16"(23)	3-3/8"(85)
B6-30-316	820.030.160S	6"(160)	1-3/8"(34)	4-3/8"(110)
B8-30-316	820.030.200S	8"(200)	1-1/2"(37)	5-7/16"(137)
B10-30-316	820.030.250S	10"(250)	1-15/16"(48)	6-1/16"(153)

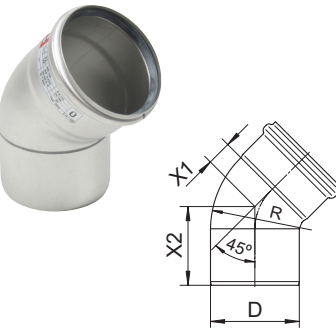

45° 1/8 Bend Dimensional Chart

Model No.	Global Part #	D	X1	X2
B1.5-45-316	820.045.040S	1.5"(40)	13/16"(21)	2-1/4"(58)
B2-45-316	820.045.050S	2"(50)	7/8"(21)	2-3/8"(60)
B3-45-316	820.045.075S	3"(75)	1-1/8"(28)	3"(76)
B4-45-316	820.045.110S	4"(110)	1-1/2"(38)	3-11/16"(93)
B6-45-316	820.045.160S	6"(160)	1-15/16"(49)	5-3/16"(131)
B8-45-316	825.045.200S	8"(200)	5-3/8"(136)	9-3/16"(234)
B10-45-316	825.045.250S	10"(250)	6-15/16"(176)	11"(280)



90° 1/4 Bend Dimensional Chart

Model No.	Global Part #	D	X1	X2
B1.5-90-316	820.090.040S	1.5"(40)	1-1/4"(32)	3-1/8"(79)
B2-90-316	820.090.050S	2"(50)	1-7/16"(35)	3-7/16"(86)
B3-90-316	820.090.075S	3"(75)	1-15/16"(48)	4-1/4"(107)
B4-90-316	820.090.110S	4"(110)	2-11/16"(68)	5-5/16"(134)
B6-90-316	820.090.160S	6"(160)	3-15/16"(99)	7-1/8"(181)
B8-90-316	825.090.200S	8"(200)	11-3/4"(299)	15-5/8"(397)
B10-90-316	825.090.250S	10"(250)	15"(350)	19-1/16"(484)

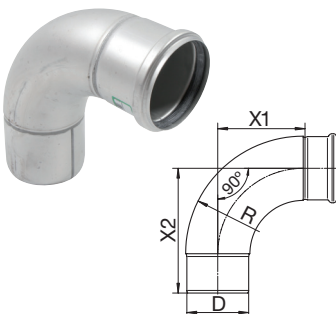

90° Degree Sweep 1/4 Bend Dimensional Chart

Model No.	Global Part #	D	X1	X2	R
B2-90S-316	825.090.050S	2"(50)	3"(77)	4-15/16"(125)	3-13/16"(97)
B3-90S-316	825.090.075S	3"(75)	4-1/8"(105)	6-1/8"(155)	5-1/4"(133)
B4-90S-316	825.090.110S	4"(110)	6-5/16"(160)	8-3/4"(222)	8-1/4"(209)
B6-90S-316	825.090.160S	6"(160)	9-3/4"(247)	12-11/16"(322)	12-5/16"(313)

Stainless Steel Fittings

Tees

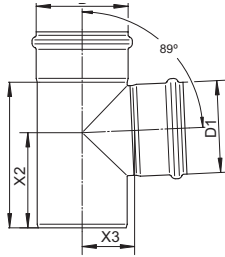

90° Tee Dimensional Chart

Model No.	Global Part #	D	D1	X	X2	X3
T1.5x1.5-90-316	830.040.040S	1.5"(40)	1.5"(40)	4"(101)	2-3/4"(69)	1-3/16"(30)
T2x1.5-90-316	830.040.050S	2"(50)	1.5"(40)	4-3/16"(106)	2-13/16"(71)	1-3/8"(35)
T2x2-90-316	830.050.050S	2"(50)	2"(50)	4"(101)	2-13/16"(71)	1-1/4"(31)
T3x2-90-316	830.050.075S	3"(75)	2"(50)	5-5/16"(134)	3-7/8"(98)	1-3/4"(44)
T4x2-90-316	830.050.110S	4"(110)	2"(50)	5"(127)	3-11/16"(93)	2-7/16"(61)
T3x3-90-316	830.075.075S	3"(75)	3"(75)	5-5/16"(134)	3-9/16"(90)	1-7/8"(47)
T4x3-90-316	830.075.110S	4"(110)	3"(75)	5-13/16"(147)	4-1/8"(104)	2-9/16"(65)
T4x4-90-316	830.110.110S	4"(110)	4"(110)	7"(178)	4-5/8"(117)	2-9/16"(64)
T6x4-90-316	830.110.160S	6"(160)	4"(110)	9-1/16"(230)	6"(152)	3-1/2"(88)
T6x6-90-316	830.160.160S	6"(160)	6"(160)	11-1/8"(282)	7-1/4"(184)	3-7/8"(98)
T8x6-90-316	830.160.200S	8"(200)	6"(160)	11-1/4"(285)	7-5/16"(186)	4-5/8"(116)
T8x8-90-316	830.200.200S	8"(200)	8"(200)	12-13/16"(325)	8-1/8"(206)	4-3/4"(120)
T10x8-90-316	830.200.250S	10"(250)	8"(200)	13-9/16"(344)	8-11/16"(220)	5-13/16"(147)
T10x10-90-316	830.250.250S	10"(250)	10"(250)	15-11/16"(399)	9-5/8"(245)	5-11/16"(144)

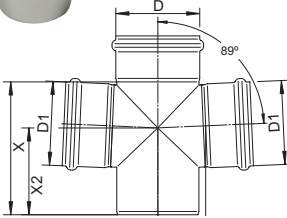

90° Double Tee (Cross) Dimensional Chart

Model No.	Global Part #	D	D1	X	X2	X3
C2x2-90-316	831.050.050	2"(50)	2"(50)	4"(101)	2-13/16"(71)	1-1/4"(31)
C3x2-90-316	831.050.075	3"(75)	2"(50)	5-5/16"(134)	3-7/8"(98)	1-3/4"(44)
C4x2-90-316	831.050.110	4"(110)	2"(50)	5"(127)	3-11/16"(93)	2-7/16"(61)
C3x3-90-316	831.075.075	3"(75)	3"(75)	5-5/16"(134)	3-9/16"(90)	1-7/8"(47)
C4x3-90-316	831.075.110	4"(110)	3"(75)	5-13/16"(147)	4-1/8"(104)	2-9/16"(64)
C4x4-90-316	831.110.110	4"(110)	4"(110)	7"(178)	4-5/8"(117)	2-9/16"(64)
C6x4-90-316	831.110.160	6"(160)	4"(110)	9-1/16"(230)	6"(152)	3-1/2"(88)
C6x6-90-316	831.160.160	6"(160)	6"(160)	11-1/8"(282)	7-1/4"(184)	3-7/8"(98)

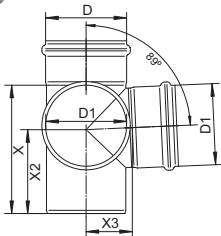

90° Double Tee (90° Offset) Dimensional Chart

Model No.	Global Part #	D	D1	X	X2	X3
DT2x2-90-316	832.050.050S	2"(50)	2"(50)	4"(101)	2-13/16"(71)	1-1/4"(31)
DT3x2-90-316	832.050.075S	3"(75)	2"(50)	5-5/16"(134)	3-7/8"(98)	1-3/4"(44)
DT4x2-90-316	832.050.110S	4"(110)	2"(50)	5"(127)	3-11/16"(93)	2-7/16"(61)
DT3x3-90-316	832.075.075S	3"(75)	3"(75)	5-5/16"(134)	3-9/16"(90)	1-7/8"(47)
DT4x3-90-316	832.075.110S	4"(110)	3"(75)	5-13/16"(147)	4-1/8"(104)	2-9/16"(64)
DT4x4-90-316	832.110.110S	4"(110)	4"(110)	7"(178)	4-5/8"(117)	2-9/16"(64)
DT6x4-90-316	832.110.160S	6"(160)	4"(110)	9-1/16"(230)	6"(152)	3-1/2"(88)
DT6x6-90-316	832.160.160S	6"(160)	6"(160)	11-1/8"(282)	7-1/4"(184)	3-7/8"(98)

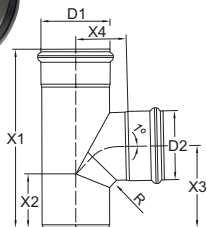

90° Degree Sanitary Sweep Tee Dimensional Chart

Model No.	Global Part #	D	D1	X1	X2	X3	X4
SS2x2-90-316	848.050.050S	2"(50)	2"(50)	6-11/16"(170)	2-3/8"(60)	3-3/16"(81)	1-13/16"(46)
SS3x2-90-316	848.050.075S	3"(75)	2"(50)	7-7/8"(199)	2-1/4"(57)	3-11/16"(94)	2-7/16"(62)
SS4x2-90-316	848.050.110S	4"(110)	2"(50)	8-1/4"(209)	1-13/16"(47)	4-1/16"(103)	3-1/8"(80)
SS3x3-90-316	848.075.075S	3"(75)	3"(75)	9"(229)	2-15/16"(75)	5"(127)	3-3/8"(86)
SS4x3-90-316	848.075.110S	4"(110)	3"(75)	9-3/8"(239)	2-1/4"(58)	4-1/2"(115)	3-3/8"(86)
SS4x4-90-316	848.110.110S	4"(110)	4"(110)	11-7/16"(290)	3-1/2"(88)	5-7/16"(138)	3-3/8"(86)
SS6x4-90-316	848.110.160S	6"(160)	4"(110)	12-1/16"(306)	3-5/16"(84)	6-7/16"(164)	4-1/2"(115)
SS6x6-90-316	848.160.160S	6"(160)	6"(160)	14-5/16"(363)	4-1/2"(115)	7-1/4"(184)	4-13/16"(122)

Stainless Steel Fittings

Wyes

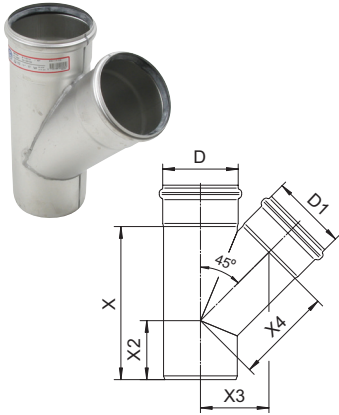

45° Wye Dimensional Chart

Model No.	Global Part #	D	D1	X	X2	X3	X4
W1.5x1.5-45-316	838.040.040S	1.5"(40)	1.5"(40)	4-5/8"(118)	2-1/4"(57)	2-1/2"(63)	1-3/4"(45)
W2x1.5-45-316	838.040.050S	2"(50)	1.5"(40)	4-11/16"(119)	2-3/16"(55)	2-13/16"(71)	2"(50)
W2x2-45-316	838.050.050S	2"(50)	2"(50)	4-7/8"(123)	2-1/4"(57)	2-13/16"(71)	2"(50)
W3x2-45-316	838.050.075S	3"(75)	2"(50)	5-1/2"(139)	2-1/4"(57)	3-9/16"(89)	2-1/2"(63)
W4x2-45-316	838.050.110S	4"(110)	2"(50)	5-5/8"(142)	1-11/16"(42)	4-1/2"(114)	3-1/4"(81)
W3x3-45-316	838.075.075S	3"(75)	3"(75)	6-7/8"(174)	2-15/16"(74)	4-3/16"(105)	2-15/16"(74)
W4x3-45-316	838.075.110S	4"(110)	3"(75)	7"(177)	2-3/8"(60)	5-1/8"(130)	3-5/8"(92)
W4x4-45-316	838.110.110S	4"(110)	4"(110)	9"(228)	3-1/2"(88)	5-11/16"(144)	4-1/16"(102)
W6x4-45-316	838.110.160S	6"(160)	4"(110)	9-15/16"(252)	3-3/16"(80)	7-1/16"(180)	5-1/16"(128)
W6x6-45-316	838.160.160S	6"(160)	6"(160)	12-11/16"(322)	4-9/16"(115)	8-1/2"(216)	6"(151)
W8x6-45-316	838.160.200S	8"(200)	6"(160)	13-13/16"(351)	4-7/8"(123)	9-1/2"(242)	6-3/4"(172)
W8x8-45-316	838.200.200S	8"(200)	8"(200)	16"(407)	6"(151)	10-1/2"(266)	7-7/16"(189)
W10x8-45-316	838.200.250S	10"(250)	8"(200)	16-11/16"(424)	5-9/16"(141)	11-3/4"(299)	8-3/8"(212)
W10x10-45-316	838.250.250S	10"(250)	10"(250)	19-13/16"(504)	7"(177)	12-13/16"(326)	13"(330)

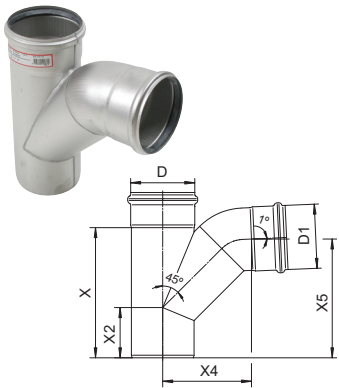

45° Combination Wye & 1/8° Bend Dimensional Chart

Model No.	Global Part #	D	D1	X	X2	X4	X5
WB-2x2-90-316	839.050.050S	2"(50)	2"(50)	4-7/8"(123)	2-1/4"(57)	3-3/16"(80)	4-13/16"(121)
WB-3x2-90-316	839.050.075S	3"(75)	2"(50)	5-1/2"(139)	2-1/4"(57)	3-5/8"(92)	5-1/16"(128)
WB-4x2-90-316	839.050.110S	4"(110)	2"(50)	5-5/8"(142)	1-11/16"(42)	4-3/8"(110)	5-1/4"(132)
WB-3x3-90-316	839.075.075S	3"(75)	3"(75)	6-7/8"(174)	2-15/16"(74)	4-5/16"(108)	6-5/16"(160)
WB-4x3-90-316	839.075.110S	4"(110)	3"(75)	7"(178)	2-3/8"(60)	4-15/16"(125)	6-5/16"(160)
WB-4x4-90-316	839.110.110S	4"(110)	4"(110)	9"(228)	3-1/2"(88)	6-1/8"(155)	8-5/16"(211)
WB-6x4-90-316	839.110.160S	6"(160)	4"(110)	9-15/16"(252)	3-3/16"(80)	7-1/8"(180)	8-15/16"(227)
WB-6x6-90-316	839.160.160S	6"(160)	6"(160)	12-11/16"(322)	4-9/16"(115)	8-5/8"(219)	11-3/4"(298)

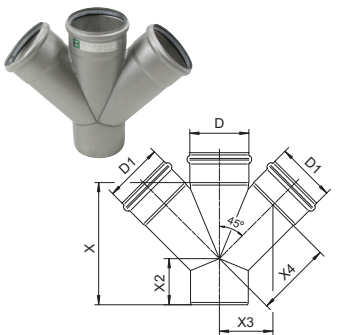

45° Double Wye Dimensional Chart

Model No.	Global Part #	D	D1	X	X2	X3	X4
DW2x2-45-316	836.050.050S	2"(50)	2"(50)	4-7/8"(123)	2-1/4"(57)	2"(50)	2-13/16"(71)
DW3x2-45-316	836.050.075S	3"(75)	2"(50)	5-1/2"(139)	2-1/4"(57)	2-1/2"(63)	3-9/16"(89)
DW4x2-45-316	836.075.075S	4"(110)	2"(50)	5-5/8"(142)	1-11/16"(42)	3-1/4"(81)	4-1/2"(114)
DW3x3-45-316	836.050.110S	3"(75)	3"(75)	6-7/8"(174)	2-15/16"(74)	2-15/16"(74)	4-3/16"(105)
DW4x3-45-316	836.075.110S	4"(110)	3"(75)	7"(178)	2-3/8"(60)	3-5/8"(92)	5-1/8"(130)
DW4x4-45-316	836.110.110S	4"(110)	4"(110)	9"(228)	3-1/2"(88)	4-1/16"(102)	5-11/16"(144)
DW6x4-45-316	836.110.160S	6"(160)	4"(110)	9-15/16"(252)	3-3/16"(80)	5-1/16"(128)	7-1/16"(180)
DW6x6-45-316	836.160.160S	6"(160)	6"(160)	12-11/16"(322)	4-9/16"(115)	6"(151)	8-1/2"(216)

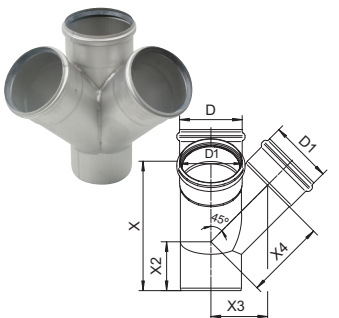

45° Double Wye (90 Degree Offset) Dimensional Chart

Model No.	Global Part #	D	D1	X	X2	X3	X5
OW2x2-45-316	837.050.050S	2"(50)	2"(50)	4-7/8"(123)	2-1/4"(57)	2"(50)	2-13/16"(71)
OW3x2-45-316	837.050.075S	3"(75)	2"(50)	5-1/2"(139)	2-1/4"(57)	2-1/2"(63)	3-9/16"(89)
OW4x2-45-316	837.050.110S	4"(110)	2"(50)	5-5/8"(142)	1-11/16"(42)	3-1/4"(81)	4-1/2"(114)
OW3x3-45-316	837.075.075S	3"(75)	3"(75)	6-7/8"(174)	2-15/16"(74)	2-15/16"(74)	4-3/16"(105)
OW4x3-45-316	837.075.110S	4"(110)	3"(75)	7"(178)	2-3/8"(60)	3-5/8"(92)	5-1/8"(130)
OW4x4-45-316	837.110.110S	4"(110)	4"(110)	9"(228)	3-1/2"(88)	4-1/16"(102)	5-11/16"(144)
OW6x4-45-316	837.110.160S	6"(160)	4"(110)	9-15/16"(252)	3-3/16"(80)	5-1/16"(128)	7-1/16"(180)
OW6x6-45-316	837.160.160S	6"(160)	6"(160)	12-11/16"(322)	4-9/16"(115)	6"(151)	8-1/2"(216)

Stainless Steel Fittings

Access Pipes

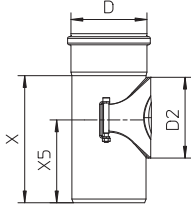

Straight Access Pipe Dimensional Chart

Model No.	Global Part #	D	D2	X	X5
AP-3-316	840.075.075S	3"(75)	3-3/16"(80)	5-5/16"(134)	3-5/8"(92)
AP-4-316	840.110.110S	4"(110)	4-3/4"(120)	7-3/8"(188)	4-7/8"(123)
AP-6-316	840.160.160S	6"(160)	4-3/4"(120)	10-11/16"(271)	8-3/16"(208)
AP-8-316	840.200.200S	8"(200)	4-3/4"(120)	11-1/16"(281)	8-3/16"(208)

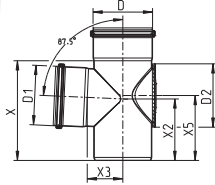

90° Access Tee Dimensional Chart

Model No.	Global Part #	D	D1	D2	X	X2	X3	X5
AT-4x4-316	834.110.110S	4"(110)	4"(110)	4-3/4"(120)	7-7/16"(189)	4-5/8"(117)	2-11/16"(67)	4-7/8"(123)
AT-6x6-316	834.160.160S	6"(160)	6"(160)	4-3/4"(120)	10-11/16" (271)	6-15/16"(176)	3-7/16"(86)	8-3/16"(208)

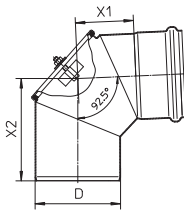

90° Access Bend Dimensional Chart

Model No.	Global Part #	D	X1	X2
AB-3-316	822.090.075S	3"(75)	2-1/16"(52)	4-1/16"(102)
AB-4-316	822.090.110S	4"(110)	3"(75)	5-1/4"(132)
AB-6-316	822.090.160S	6"(160)	4-3/16"(106)	8-1/16"(205)

Stainless Steel Fittings

Couplings & Expansion Sockets

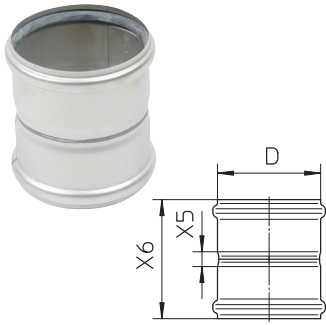

Double Coupling Dimensional Chart

Model No.	Global Part #	D	X5	X6
DC-1.5-316	841.040.040S	1.5"(40)	13/16"(20)	4-1/16"(104)
DC-2-316	841.050.050S	2"(50)	9/16"(13)	3-7/8"(97)
DC-3-316	841.075.075S	3"(75)	13/16"(20)	4-3/4"(120)
DC-4-316	841.110.110S	4"(110)	11/16"(16)	5-1/8"(130)
DC-6-316	841.160.160S	6"(160)	13/16"(20)	6-3/8"(162)
DC-8-316	841.200.200S	8"(200)	13/16"(20)	7-7/8"(200)
DC-10-316	841.250.250S	10"(250)	1-3/16"(30)	9-11/16"(246)

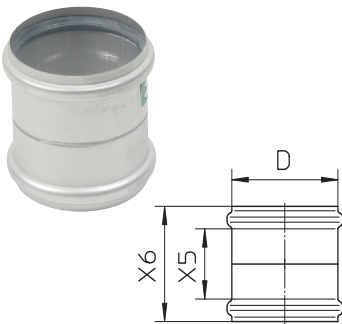

Double Slip Coupling Dimensional Chart

Model No.	Global Part #	D	X5	X6
DSC-1.5-316	842.040.040S	1.5"(40)	3"(76)	4-1/16"(104)
DSC-2-316	842.050.050S	2"(50)	2-13/16"(71)	3-7/8"(97)
DSC-3-316	842.075.075S	3"(75)	3-5/8"(91)	4-3/4"(120)
DSC-4-316	842.110.110S	4"(110)	3-7/8"(97)	5-1/8"(130)
DSC-6-316	842.160.160S	6"(160)	4-11/16"(118)	6-3/8"(162)
DSC-8-316	842.200.200S	8"(200)	5-13/16"(147)	7-7/8"(200)
DSC-10-316	842.250.250S	10"(250)	6-13/16"(173)	9-11/16"(246)

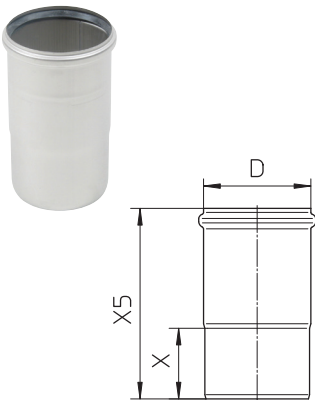

Expansion Socket Dimensional Chart

Model No.	Global Part #	D	X	X5
ES-1.5-316	843.095.040S	1.5"(40)	2-3/16"(55)	5-7/8"(150)
ES-2-316	843.105.050S	2"(50)	2-1/16"(52)	6-5/16"(159)
ES-3-316	843.115.075S	3"(75)	2-1/4"(57)	6-7/8"(175)
ES-4-316	843.125.110S	4"(110)	2-15/16"(74)	7-7/8"(200)
ES-6-316	843.182.160S	6"(160)	4-5/8"(116)	11-1/2"(292)

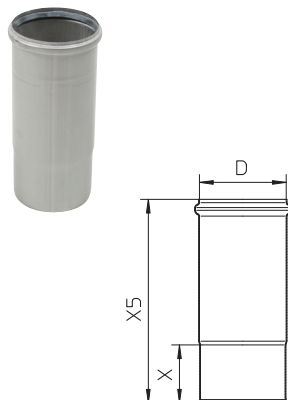

Long Expansion Socket Dimensional Chart

Model No.	Global Part #	D	X	X5
LES-2-316	869.143.050S	2"(50)	2-1/16"(52)	7-7/8"(200)
LES-3-316	869.163.075S	3"(75)	2-1/4"(57)	8-7/8"(225)
LES-4-316	869.181.110S	4"(110)	2-15/16"(74)	10-1/4"(260)
LES-6-316	869.238.160S	6"(160)	4-5/8"(116)	14-3/16"(360)
LES-8-316	869.300.200S	8"(200)	4-7/16"(112)	16-9/16"(420)

Stainless Steel Fittings

Increasesers & Reducers

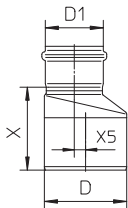

Eccentric Increaser Dimensional Chart

Model No.	Global Part #	D	D1	X	X5
EI-2x1.5-316	850.040.050S	2"(50)	1.5"(40)	3-7/8"(85)	3/16"(5)
EI-3x2-316	850.050.075S	3"(75)	2"(50)	3-1/4"(82)	5/16"(7)
EI-4x2-316	850.050.100S	4"(110)	2"(50)	4-5/16"(108)	1"(25)
EI-4x3-316	850.075.110S	4"(110)	3"(75)	4-3/8"(111)	5/8"(15)
EI-6x3-316	850.075.160S	6"(160)	3"(75)	6-3/4"(172)	1-1/2"(37)
EI-6x4-316	850.110.160S	6"(160)	4"(110)	5-11/32"(135)	7/8"(22)
EI-8x6-316	850.160.200S	8"(200)	6"(160)	6-1/2"(165)	13/16"(20)

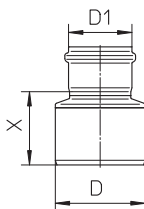

Concentric Increaser Dimensional Chart

Model No.	Global Part #	D	D1	X
CI-3x2-316	850.050.075.CS	3"(75)	2"(50)	3-1/16"(77)
CI-4x2-316	850.050.110.CS	4"(110)	2"(50)	3-9/16"(89)
CI-4x3-316	850.075.110.CS	4"(110)	3"(75)	3-9/16"(90)
CI-6x4-316	850.110.160.CS	6"(160)	4"(110)	4-7/16"(112)
CI-8x6-316	850.160.200S	8"(200)	6"(160)	6-7/16"(164)
CI-10x8-316	850.200.250S	10"(250)	8"(200)	6-5/8"(168)

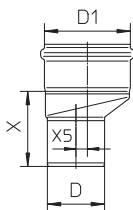

Eccentric Reducer Dimensional Chart

Model No.	Global Part #	D	D1	X	X5
ER-2x3-316	850.075.050S	2"(50)	3"(75)	3-1/8"(79)	5/16"(7)
ER-2x4-316	850.100.050S	2"(50)	4"(110)	3-3/4"(94)	1"(25)
ER-3x4-316	850.100.075S	3"(75)	4"(110)	3-7/8"(98)	5/8"(15)
ER-4x6-316	850.160.110S	4"(110)	6"(160)	4-5/8"(117)	7/8"(22)
ER-6x8-316	850.200.160S	6"(160)	8"(200)	6"(153)	13/16"(20)
ER-8x10-316	850.250.200S	8"(200)	10"(250)	7-7/16"(189)	1"(25)

Stainless Steel Fittings

Adaptors

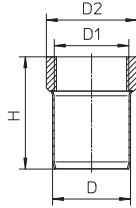

Female Adaptor Dimensional Chart

Model No.	Global Part #	D	D1	H	H5
FA-1-1/2x1-1/4-316	885.032.040S	1-1/2"(40)	1-1/4"(32)	2-13/16"(70)	1-13/16"(45)
FA-1-1/2x1-1/2-316	885.040.040S	1-1/2"(40)	1-1/2"(40)	2-7/8"(73)	2-1/4"(57)
FA-2x1-316	885.025.050S	2"(50)	1"(25)	3-11/16"(93)	1-5/8"(40)
FA-2x1-1/4-316	885.032.050S	2"(50)	1-1/4"(32)	2-7/8"(72)	1-15/16"(48)
FA-2x1-1/2-316	885.040.050S	2"(50)	1-1/2"(40)	2-7/8"(72)	2-5/16"(58)
FA-2x2-316	885.050.050S	2"(50)	2"(50)	3-1/16"(77)	2-11/16"(67)

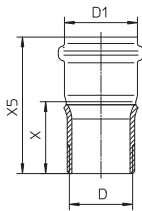

Male Adaptor Dimensional Chart

Model No.	Global Part #	D	D1	X	X5
MA-1-1/4x2-316	886.050.032S	1-1/4"(32)	2"(50)	3-7/8"(97)	2"(50)
MA-1-1/2x2-316	886.050.040S	1-1/2"(40)	2"(50)	3-7/8"(98)	2-1/16"(52)
MA-2x2-316	886.050.050S	2"(50)	2"(50)	3-7/8"(98)	2-1/16"(52)

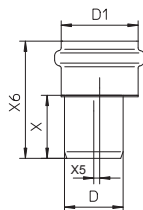

Side Inlet Adaptor Dimensional Chart

Model No.	Global Part #	D	D1	X	X5	X6
CSIA-1-1/4x2-316	850.050.032S	1-1/4"(32)	2"(50)	2-1/16"(52)	-	3-15/16"(99)
ESIA-1-1/2x2-316	850.050.040S	1-1/2"(40)	2"(50)	1-3/4"(43)	3/16"(4)	3-3/16"(80)

90 Degree Long Radius Bend

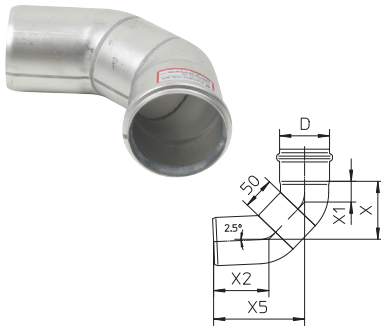

Model No. 316L / Global Part #	D	X	X1	X2	X5
821.000.050S	2"(50)	3"(77)	1"(26)	2-13/16"(72)	4-3/4"(120)
821.000.075S	3"(75)	3-9/16"(90)	1-1/4"(32)	3-3/8"(86)	5-9/16"(141)
821.090.050S	2"(50)	8-9/16"(217)	7/8"(22)	2-13/16"(72)	10-3/16"(259)
821.090.075S	3"(75)	9-1/16"(23)	1-1/16"(27)	3-7/16"(87)	11"(280)
821.090.110S	4"(110)	9-13/16"(250)	1-1/2"(38)	4-1/16"(103)	12-1/16"(307)
821.090.160S	6"(160)	11-1/8"(282)	5-1/8"(130)	5-1/8"(130)	13-15/16"(354)

DIN Socket Flange Adaptor – PN16 DIN 2633/EN1092-1

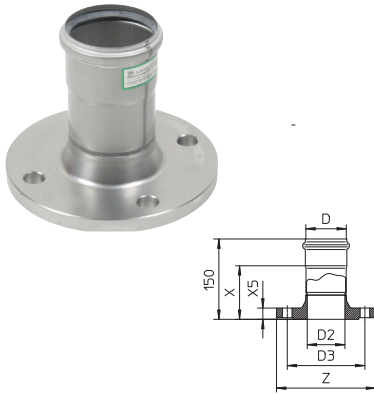

Model No. 316L / Global Part #	D	Z	D2	D3	X	X5
854.200.040S	1.5"(40)	5-15/16"(150)	1-11/16"(43)	4"(110)	4-1/14"(108)	11/16"(18)
854.200.050S	2"(50)	5-15/16"(150)	1-11/16"(43)	4"(110)	4-1/14"(108)	3/4"(19)
854.200.075S	3"(75)	7-1/4"(185)	2-3/4"(70)	5-11/16"(145)	3-15/16"(100)	13/16"(21)
854.300.040S	1.5"(40)	6-1/2"(165)	2-3/16"(55)	4-15/16"(125)	4-1/14"(108)	11/16"(18)
854.300.050S	2"(50)	6-1/2"(165)	2"(51)	4-15/16"(125)	4-1/14"(108)	13/16"(21)
854.300.110S	4"(110)	8-11/16"(220)	4-3/16"(107)	7-1/16"(180)	3-3/4"(95)	15/16"(23)

DIN Spigot Flange Adaptor – PN16 DIN 2633/EN1092-1

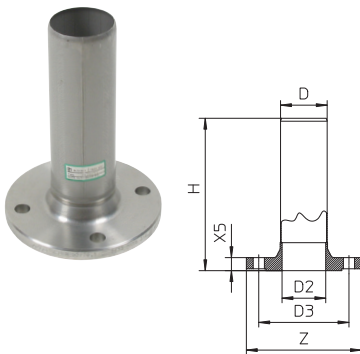

Model No. 316L / Global Part #	D	Z	H	D2	D3	X5
854.210.040S	1.5"(40)	5-15/16"(150)	5-15/16"(150)	1-11/16"(43)	4"(110)	11/16"(18)
854.210.050S	2"(50)	5-15/16"(150)	9-3/16"(234)	1-11/16"(43)	4"(110)	3/4"(19)
854.210.075S	3"(75)	7-1/4"(185)	9-5/8"(245)	2-3/4"(70)	5-11/16"(145)	13/16"(21)
854.310.040S	1.5"(40)	6-1/2"(165)	5-15/16"(150)	2-3/16"(55)	4-15/16"(125)	11/16"(18)
854.310.050S	2"(50)	6-1/2"(165)	7-9/16"(192)	2"(51)	4-15/16"(125)	13/16"(21)
854.310.110S	4"(110)	8-11/16"(220)	10-3/16"(259)	4-3/16"(107)	7-1/16"(180)	15/16"(23)

ANSI Socket Flange Adaptor – ANSI B16.5

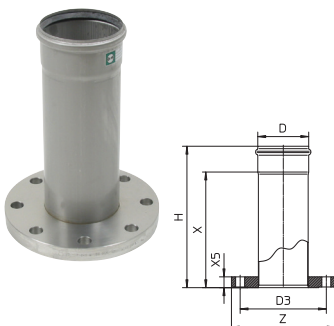

Model No. 316L / Global Part #	D	Z	H	D3	X	X5
854.025.040S	1.5"(40)	6"(152)	11-1/2"(292)	4-3/4"(121)	9-13/16"(250)	3/4"(19)
854.025.050S	2"(50)	6"(152)	11-11/16"(297)	4-3/4"(121)	10"(255)	13/16"(20)
854.025.075S	3"(75)	7-1/2"(191)	12"(305)	6"(153)	10"(255)	15/16"(24)
854.025.110S	4"(110)	9"(229)	12-3/4"(312)	7-1/2"(191)	10"(255)	15/16"(24)
854.025.160S	6"(160)	11"(279)	12-7/8"(328)	9-1/2"(242)	10"(255)	15/16"(24)

ANSI Spigot Flange Adaptor — ANSI B16.5

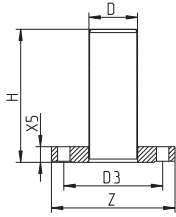
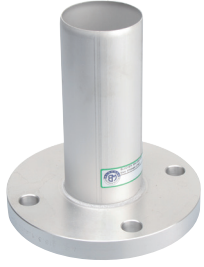

<i>Model No. 316L / Global Part #</i>	<i>D</i>	<i>Z</i>	<i>H</i>	<i>D3</i>	<i>X5</i>
854.035.040S	1.5"(40)	6"(152)	7-7/8"(200)	4-3/4"(121)	3/4"(19)
854.035.050S	2"(50)	6"(152)	7-3/4"(197)	4-3/4"(121)	3/4"(19)
854.035.075S	3"(75)	7-1/2"(191)	8-1/16"(205)	6"(152)	15/16"(24)
854.035.110S	4"(110)	9"(229)	8-3/8"(212)	7-1/2"(191)	15/16"(24)

Toilet Adaptor

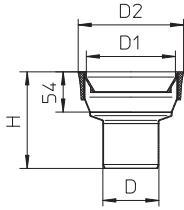

<i>Model No. 316L / Global Part #</i>	<i>D</i>	<i>D1</i>	<i>D2</i>	<i>H</i>
855.090.075S	3"(75)	4"(110)	5-9/16"(141)	5-1/8"(129)
855.090.110S	4"(110)	4"(110)	5-9/16"(141)	4-15/16"(124)

Bulkhead Penetration with Welding Sleeve

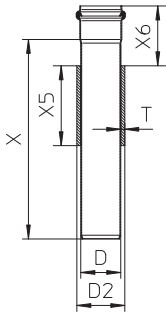

<i>Model No. 316L / Global Part #</i>	<i>D</i>	<i>D2</i>	<i>X</i>	<i>X5</i>	<i>X6</i>	<i>T</i>
866.025.040.10FS	1.5"(40)	2"(50)	9-13/16"(250)	3-15/16"(100)	3"(75)	3/16"(5)
866.025.050.10FS	2"(50)	2-3/8"(60)	9-13/16"(250)	3-15/16"(100)	3"(75)	3/16"(5)
866.025.075.10FS	3"(75)	3-3/8"(85)	9-13/16"(250)	3-15/16"(100)	3"(75)	3/16"(5)
866.025.110.10FS	4"(110)	4-3/4"(120)	9-13/16"(250)	3-15/16"(100)	3"(75)	3/16"(5)
866.025.160.10FS	6"(160)	6-11/16"(170)	9-13/16"(250)	3-15/16"(100)	3"(75)	3/16"(5)

Wash Basin Penetration with Welding Sleeve

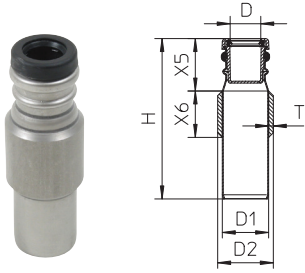

Model No. 316L / Global Part #	D	D1	H	D2	X5	X6	T
866.032.050.05S	1-1/4"(32)	2"(50)	6-13/16"(173)	2-3/8"(60)	2-1/4"(57)	2"(50)	3/16"(5)

Toilet Penetration for Vacuum System with Welding Sleeve

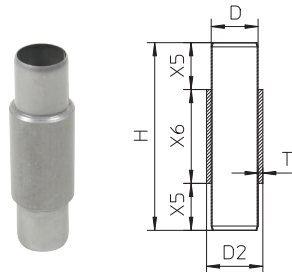

Model No. 316L / Global Part #	D	H	D2	X5	X6	T
867.020.040.10S	1.5"(40)	7-7/8"(200)	2"(50)	2"(50)	3-15/16"(100)	3/16"(5)
867.020.050.10S	2"(50)	7-7/8"(200)	2-3/8"(60)	2"(50)	3-15/16"(100)	3/16"(5)

Deck Penetration with Welding Flange

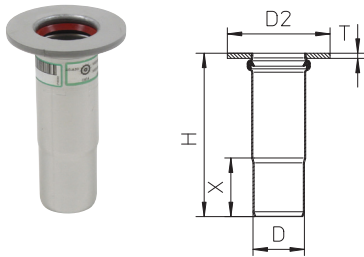

Model No. 316L / Global Part #	D	H	D2	X	T
868.100.040FS	1.5"(40)	6"(152)	3-9/16"(90)	2-3/16"(55)	3/16"(5)
868.105.050FS	2"(50)	6-1/4"(159)	3-15/16"(100)	2-1/4"(57)	3/16"(5)
868.115.075FS	3"(75)	6-7/8"(175)	5-5/16"(135)	2-7/16"(62)	3/16"(5)
868.125.110FS	4"(110)	7-7/8"(200)	6-5/16"(160)	3-1/8"(79)	3/16"(5)

Socket Deck Penetration with Welding Sleeve

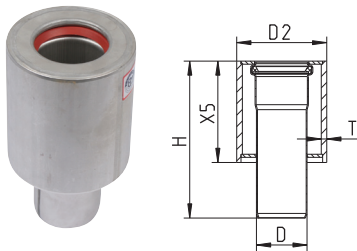

Model No. 316L / Global Part #	D	H	D2	X5	T
870.000.040FS	1.5"(40)	5-15/16"(151)	3-9/16"(90)	3-15/16"(100)	3/16"(5)
870.000.050FS	2"(50)	6-1/8"(155)	3-9/16"(90)	3-15/16"(100)	3/16"(5)
870.000.075FS	3"(75)	6-9/16"(167)	4-1/4"(108)	3-15/16"(100)	3/16"(5)
870.000.110FS	4"(110)	6-9/16"(167)	5-1/2"(140)	3-15/16"(100)	3/16"(5)

Deck Penetration with Welding Sleeve

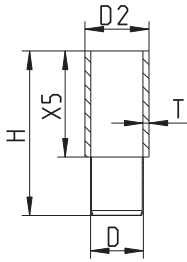

<i>Model No. 316L / Global Part #</i>	<i>D</i>	<i>H</i>	<i>D2</i>	<i>X5</i>	<i>T</i>
872.050.040S	1.5"(40)	5-15/16"(150)	2"(50)	3-15/16"(100)	3/16"(5)
872.060.050S	2"(50)	6-1/8"(155)	2-3/8"(60)	3-15/16"(100)	3/16"(5)
872.076.075S	3"(75)	6-5/16"(160)	3" (76)	3-15/16"(100)	3/16"(5)
872.089.075S	3"(75)	6-5/16"(160)	3-1/2" (89)	3-15/16"(100)	3/16"(5)
872.114.110S	4"(110)	6-1/8"(155)	4-1/2" (114)	3-15/16"(100)	3/16"(5)

Aluminum Deck Penetration with Bi-Metal Welding Flange

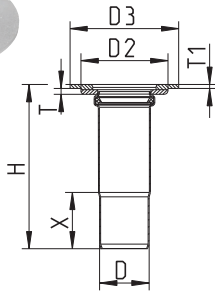

<i>Model No. 316L / Global Part #</i>	<i>D</i>	<i>H</i>	<i>D2</i>	<i>D3</i>	<i>X</i>	<i>T</i>	<i>T1</i>
878.105.050S	2"(50)	6-9/16"(166)	3-7/16"(88)	4-3/16" (110)	2-1/4"(57)	1/4"(6)	3/16"(4)
878.115.075S	3"(75)	7-3/16"(182)	4-7/16"(113)	5-5/16" (136)	2-7/16"(62)	1/4"(6)	3/16"(4)
878.125.110S	4"(110)	8-1/8"(207)	5-13/16"(148)	6-3/4" (172)	3-1/8"(79)	1/4"(6)	3/16"(4)

Sealing Rings

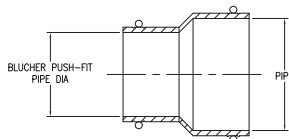
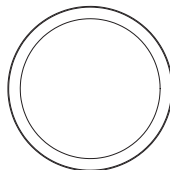
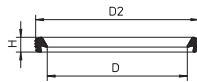
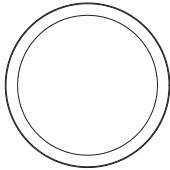
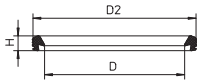
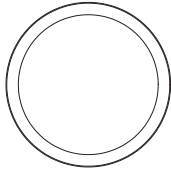
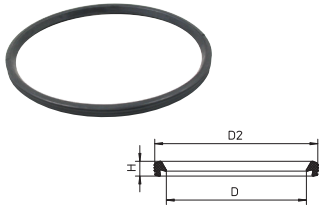

EPDM Sealing Ring Black (Standard) Dimensional Chart

Model No.	Global Part #	D	H	D2
EPDM-1-1/4	801.EPDM.032	1-1/4"(32)	1/4"(6)	1-5/8"(40)
EPDM-1-1/2	801.EPDM.040	1-1/2"(40)	3/8"(8)	2-1/16"(52)
EPDM-2	801.EPDM.050	2"(50)	3/8"(8)	2-1/2"(62)
EPDM-3	801.EPDM.075	3"(75)	3/8"(8)	3-7/16"(87)
EPDM-4	801.EPDM.110	4"(110)	3/8"(9)	4-15/16"(124)
EPDM-6	801.EPDM.160	6"(160)	1/2"(12)	7-1/8"(180)
EPDM-8	801.EPDM.200	8"(200)	9/16"(13)	8-13/16"(224)
EPDM-10	801.EPDM.250	10"(250)	3/4"(19)	11-1/8"(282)

FPM Sealing Ring Green (High Temperature Applications) Dimensional Chart

Model No.	Global Part #	D	H	D2
FPM-1.5	801.FPM.040	1.5"(40)	3/8"(8)	2-1/16"(52)
FPM-2	801.FPM.050	2"(50)	3/8"(8)	2-1/2"(62)
FPM-3	801.FPM.075	3"(75)	3/8"(8)	3-7/16"(87)
FPM-4	801.FPM.110	4"(110)	3/8"(9)	4-15/16"(124)
FPM-6	801.FPM.160	6"(160)	1/2"(12)	7-1/8"(180)
FPM-8	801.FPM.200	8"(200)	9/16"(13)	8-13/16"(224)
FPM-10	801.FPM.250	10"(250)	3/4"(19)	11-1/8"(282)

NBR Sealing Ring Yellow (Petroleum Applications)

Model No.	Global Part #	D	H	D2
NBR-1.5	801.NBR.040	1.5"(40)	3/8"(8)	2-1/16"(52)
NBR-2	801.NBR.050	2"(50)	3/8"(8)	2-1/2"(62)
NBR-3	801.NBR.075	3"(75)	3/8"(8)	3-7/16"(87)
NBR-4	801.NBR.110	4"(110)	3/8"(9)	4-15/16"(124)
NBR-6	801.NBR.160	6"(160)	1/2"(12)	7-1/8"(180)
NBR-8	801.NBR.200	8"(200)	9/16"(13)	8-13/16"(224)
NBR-10	801.NBR.250	10"(250)	3/4"(19)	11-1/8"(282)

Transition Couplings

Model No. 316L	Global Part #	BLÜCHER	Cast Iron	Sch40
BTC-1.5x1.5	N/A	1.5"(40)	1.5"	1.5"
BTC-2x2	N/A	2"(50)	2"	2"
BTC-3x3-NH	N/A	3"(75)	3"	
BTC-3x3-SCH40	N/A	3"(75)		3"
BTC-4x4-NH	N/A	4"(110)	4"	
BTC-4x4-SCH40	N/A	4"(110)		4"
BTC-6x6-NH	N/A	6"(160)	6"	
BTC-6x6-SCH40	N/A	6"(160)		6"

Traps

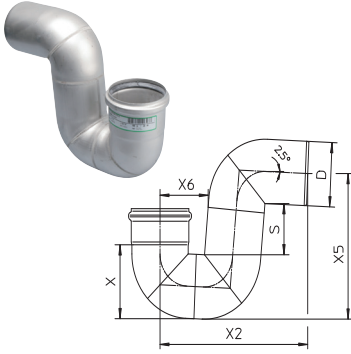

P-Trap Dimensional Chart

Model No.	Global Part #	D	S	X	X2	X5	X6
PT-2	525.090.050S	2"(50)	2-15/16"(74)	2-1/2"(63)	6-7/8"(175)	5-3/4"(145)	2-3/8"(60)
PT-3	525.090.075S	3"(75)	3-1/4"(81)	3-9/16"(89)	8-3/4"(222)	7-7/16"(189)	2-15/16"(74)
PT-4	525.090.110S	4"(110)	3-9/16"(89)	5"(126)	11-3/8"(289)	9-13/16"(249)	3-3/4"(94)
PT-6	525.090.160S	6"(160)	4-3/16"(105)	7"(178)	15-1/4"(388)	13-5/16"(338)	4-13/16"(121)

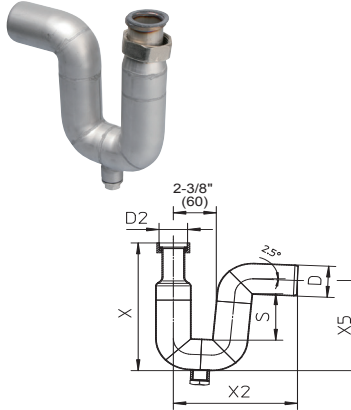

P-Trap w/Coupling & Drain Plug Dimensional Chart

Model No.	Global Part #	D	S	D2	X	X2	X5
PTC-2x1-1/4-316	525.032.050S	2"(50)	2-15/16"(74)	1-1/4"(32)	8-1/16"(205)	6-7/8"(175)	5-3/4"(145)
PTC-2x1-1/2-316	525.040.050S	2"(50)	2-15/16"(74)	1-1/2"(40)	8-1/16"(205)	6-7/8"(175)	5-3/4"(145)
PTC-2x2-316	525.050.050S	2"(50)	2-15/16"(74)	2"(50)	8-1/16"(205)	6-7/8"(175)	5-3/4"(145)

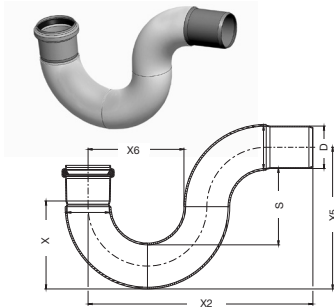

PT-L Trap Dimensional Chart

Model No.	Global Part #	D	S	X	X2	X5	X6
PT-2L	599-14979-03-S	2"(50)	3-1/2"(90)	4-1/8"(104)	10-3/8"(265)	6-5/8"(167)	4-1/2"(113)
PT-3L	599-14979-04-S	3"(75)	4-1/2"(114)	5-5/8"(143)	13-5/8"(345)	9"(228)	6"(152)
PT-4L	599-14979-05-S	4"(102)	7-5/8"(195)	8-5/8"(218)	20-7/8"(529)	14-1/4"(362)	9-3/4"(248)
PT-6L	599-14979-06-S	6"(152)	11-1/2"(293)	13"(328)	30-5/8"(779)	21-1/4"(541)	14-5/8"(373)
PT-8L	599-14979-02-S	8"(203)	13-5/8"(347)	16-5/8"(422)	40-1/8"(1020)	25-3/8"(644)	19-3/8"(492)
PT-10L	599-14979-07-S	10"(254)	17-1/8"(434)	21"(534)	49-3/4"(1263)	31-3/4"(806)	24-1/2"(622)

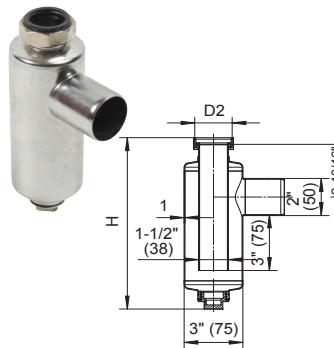

Bottle Trap Dimensional Chart

Model No.	Global Part #	D2	H
BT-1-1/4	505.032.050S	1-1/4"(32)	9-13/16"(250)
BT-1-1/2	505.040.050S	1-1/2"(40)	9-3/16"(233)
BT-2	505.050.050S	2"(50)	9-9/16"(243)

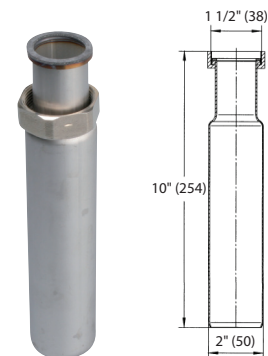

Tailpiece Adaptor Dimensional Chart

Model No.	Global Part #	Pipe Size
TA-1-1/2x2-316	851.025.040S	2"(50)

Clamps & Hangers

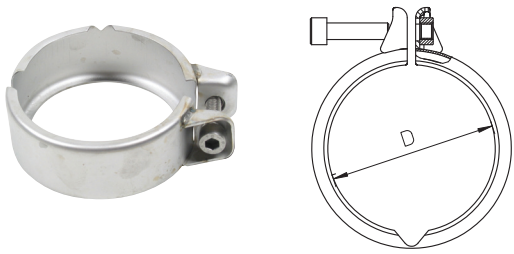

Joint Clamp Dimensional Chart

Model No.	Global Part #	D
JC-1.5	847.040.040	1.5"(40)
JC-2	847.050.050	2"(50)
JC-3	847.075.075	3"(75)
JC-4	847.110.110	4"(110)
JC-6	847.160.160	6"(160)
JC-8	847.200.200	8"(200)
JC-10	847.250.250	10"(250)

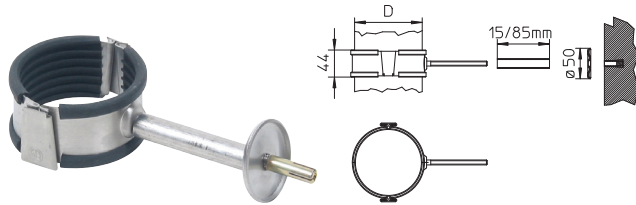

Pipe Hanger Dimensional Chart

Model No.	Global Part #	D
PH-2	860.040.050	2"(50)
PH-3	860.040.075	3"(75)
PH-4	860.040.110	4"(110)
PH-6	860.040.160	6"(160)

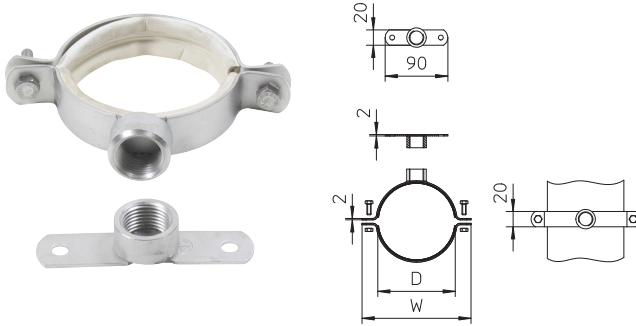

2-Piece Pipe Hanger Dimension Chart

Model No.	Global Part #	D	Thread Size
PH2-1.5-3/8	895.012.040.AGS	1.5"(40)	3/8"
PH2-1.5-1/2	895.012.040.GS	1.5"(40)	1/2" BSP
PH2-2-3/8	895.012.050.AGS	2"(50)	3/8"
PH2-2-1/2	895.012.050.GS	2"(50)	1/2" BSP
PH2-3-3/8	895.012.075.AGS	3"(75)	3/8"
PH2-3-1/2	895.012.075.GS	3"(75)	1/2" BSP
PH2-4-3/8	895.012.110.AGS	4"(110)	3/8"
PH2-4-1/2	895.012.110.GS	4"(110)	1/2" BSP
PH2-6-3/8	895.012.160.AGS	6"(160)	3/8"
PH2-6-1/2	895.012.160.GS	6"(160)	1/2" BSP

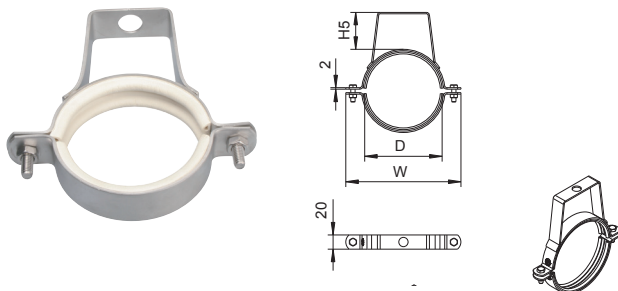

Adjustable Pipe Hanger Dimension Chart

Model No.	Global Part #	D
PHA-1.5	895.200.040S	1.5"(40)
PHA-2	895.200.050S	2"(50)
PHA-3	895.200.075S	3"(75)
PHA-4	895.200.110S	4"(110)
PHA-6	895.200.160S	6"(160)



Sway Brace

Model No.	Global Part #
SB-1	847.000.000

Socket Plugs

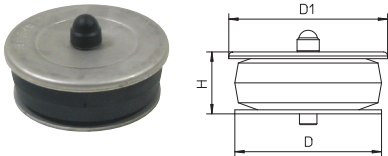
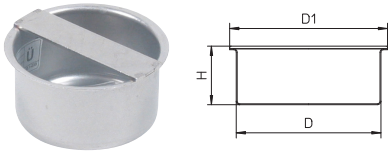

Push-In Socket Plug Dimensional Chart

Model No.	Global Part #	D	D1	H
PSP-1.5	844.000.040S	1.5"(40)	2"(50)	1-1/4"(32)
PSP-2	844.000.050S	2"(50)	2-5/16"(58)	2"(50)
PSP-3	844.000.075S	3"(75)	3-3/8"(85)	1-13/16"(45)
PSP-4	844.000.110S	4"(110)	4-3/4"(120)	1-13/16"(45)
PSP-6	844.000.160S	6"(160)	6-11/16"(170)	1-13/16"(45)
PSP-8	844.000.200S	8"(200)	8-1/4"(210)	2"(50)
PSP-10	844.000.250S	10"(250)	10-7/16"(265)	2-9/16"(65)

Compression Socket Plug Dimensional Chart

Model No.	Global Part #	D	D1	H
CSP-2	844.100.050S	2"(50)	2-3/8"(59)	1-1/4"(31)
CSP-3	844.100.075S	3"(75)	3-5/16"(83)	1-7/16"(36)
CSP-4	844.100.110S	4"(110)	4-11/16"(118)	1-7/16"(36)
CSP-6	845.000.160S	6"(160)	6-11/16"(170)	1-13/16"(45)

Cutting Tools & Accessories



Manual Pipe Cutting & Beveling Tool

Special disc cutter cuts and grips at the same time.
Do not cut fittings.

Model No.	Global Part #	Desc.
MPC-2-4	006.050.110	Manual Pipe Cutter 2"(50) to 4"(160)
MPC-2-4-R	006.050.110.R	Manual Pipe Cutter 2"(50) to 4"(160) (Refurbished)
MPC-5-8	006.125.200	Manual Pipe Cutter 5"(125) to 8"(200)
MPC-5-8-R	006.125.200.R	Manual Pipe Cutter 5"(125) to 8"(200) (Refurbished)
MPC-8-12	006.200.315	Manual Pipe Cutter 8"(200) to 12"(325)
MPC-8-12-R	006.200.315.R	Manual Pipe Cutter 8"(200) to 12"(325) (Refurbished)
MPC-S-2-4	006.000.005	Spindle for MPC-2-4 Pipe Cutter
MPC-D-2-4	006.000.000	Cutting Disc for MPC-2-4
MPC-D-5-8	006.000.001	Cutting Disc for MPC-5-8



Electric Pipe Cutting & Beveling Tool

Produces a beveled leading edge in less than 20 seconds.
Cutting discs change over quickly. Do not cut fittings.

Model No.	Global Part #	Desc.
EPC-2-6	800.050.160.US	110V Electric Pipe Cutter 2"(50) to 6"(160)
EPC-2-6-R	800.050.160.US.R	110V Electric Pipe Cutter 2"(50) to 6"(160) (Refurbished)



Cutting Oil/Joining Lubricant

Joining lubricant is required to connect pipe and fittings in a simple action.
Blucher Joining Lubricant is designed to dry out and lose its lubricity after a few days, preventing any future opening of the joint.

Model No.	Global Part #	Desc.
AT-1	007.000.000	Atomizer for Joining Lubricant or Cutting Oil
JL-1	007.100.050	Joining Lubricant (0.5 Liter)
CO-1	007.500.050	Cutting Oil (0.5 Liter)



Pipe Dimpling Tool

For pressing pipe projections on pipe. Use with Ridgid RP 330-C Press Tool

Model No.	Global Part #	Desc.
DJ-1	800.200.001	Dimpling Tool
DJ-1-R	800.200.001.R	Dimpling Tool (1 week rental)

Drains for hospitality, medical, commercial and industrial applications



Sanitary stainless steel drains and cleanouts

Sanitary applications

- Food and beverage processing
- Industrial manufacturing
- Medical facilities
- Hotels and resorts
- Commercial kitchens
- Supermarkets, restaurants, airports, etc.

Special applications

- Chemical or biohazard environments
- Marine and shipbuilding
- Rubberized or epoxy flooring
- Indirect waste

Specifications

- Stainless steel AISI 304 or 316L
- IAPMO and/or NSF listed
- ANSI load classifications to Extra Heavy Duty



Compliance with NSF/ANSI/3-A 14159-1-
Hygiene Requirements for the Design of
Meat and Poultry Processing Equipment

Pictorial Index

Washroom/Shower



BSS-100
Shower

Washroom/Shower



BSS-300
Shower

Washroom/Shower



BSR-700
Shower w/Surface
Membrane Clamp

Washroom/Shower



BSR-800
Shower w/ Surface
Membrane Clamp



BFD-110
8"x8" w/
Flashing Clamp



BFD-110-R
8" Round w/
Flashing Clamp



BFD-110-SO
8"x8" w/
Flashing Clamp



BFD-110-R-SO
8" Round w/
Flashing Clamp



BFD-130
12"x12" w/
Flashing Clamp



BFD-130-R
12" Round w/
Flashing Clamp



BFD-130-SO
12"x12" w/
Flashing Clamp



BFD-130-R-SO
12" Round w/
Flashing Clamp



BFD-210
8"x8" Adjustable



BFD-210-R
8" Round Adjustable



BFD-210-SO
8"x8" Adjustable



BFD-210-R-SO
8" Round Adjustable

Pictorial Index



BFD-230
12"x12" Adjustable



BFD-230-R
12" Round Adjustable



BFD-230-SO
12"x12" Adjustable



BFD-230-R-SO
12" Round Adjustable



BFD-320
8"x8" Sanitary



BFD-320-SO
8"x8" Sanitary



BFD-340
12"x12" Sanitary



BFD-340-SO
12"x12" Sanitary



BFD-420
8" Round Sanitary



BFD-420-SO
8" Round Sanitary



BFD-440
12" Round Sanitary



BFD-440-SO
12" Round Sanitary



BFD-510
8" Round Surface
Membrane Clamp



BFD-510-SO
8" Round Surface
Membrane Clamp



BFD-530
12" Round Surface
Membrane Clamp



BFD-530-SO
12" Round Surface
Membrane Clamp

Pictorial Index



BFD-550
8"x8" Elastomeric
Flange



BFD-560
12"x12" Elastomeric
Flange



BFD-570
HygienicPro® Floor Drain



BFD-570-SO
HygienicPro® Floor Drain
w/Side Outlet



BFD-610
Gastight Industrial



BFD-610-R
Gastight Industrial



BFD-VH
Vacuum Handles



BHD-100
Hub Drain



BTPC
Trap Primer Adaptor



BCO-110
Cleanout Pull Nipple



BCO-120
Cleanout Vacuum Cover



BCO-130
Cleanout Heavy Duty



BCO-140
Cleanout Pull Nipple



BCO-150
Cleanout Vacuum Cover



BCO-220
Cleanout w/Surface
Membrane Clamp

Pictorial Index



470.000.xxxS
Steel Deck Lower Part
w/Welding Sleeve



470.200.xxxS
Steel Deck Lower Part
w/Welding Flange



475.000.xxxS
Steel Deck Lower Part
w/Welding Sleeve



475.100.xxxS
Steel Deck Lower Part
w/Welding Sleeve



475.200.xxxS
Steel Deck Lower Part
w/Welding Flange



480.200.xxxS
Aluminum Deck Lower Part



485.200.xxxS
Aluminum Deck Lower Part



471.300.110S
Side Inlets Upper Part



472.320.110S
Resin Floors Upper Part



473.301.110S
Surface Membrane Clamp
Upper Part



472.320.110S
Welding Sleeve Upper Part

Installation examples

On grade

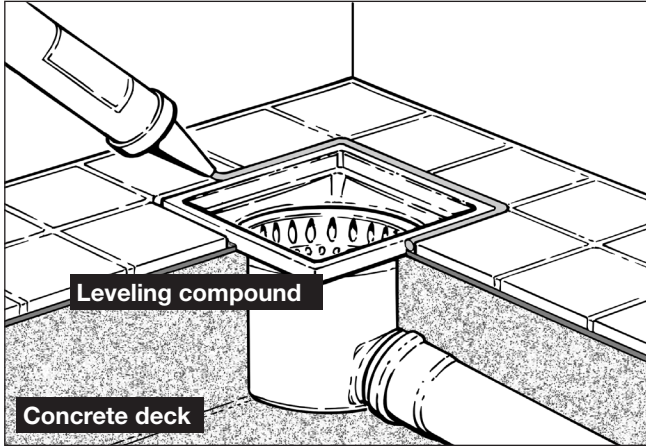

Sheet flooring

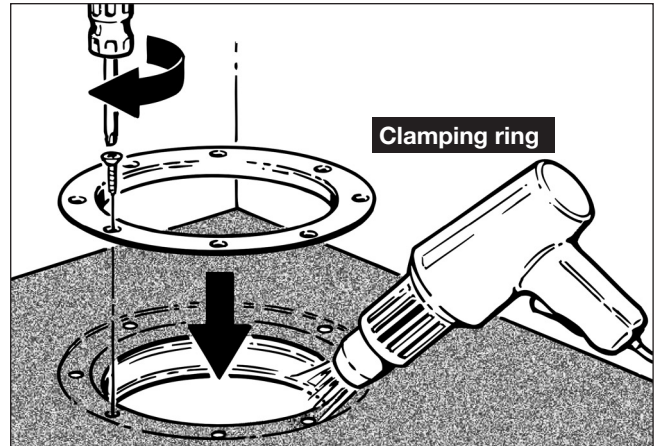

Above ground with membrane

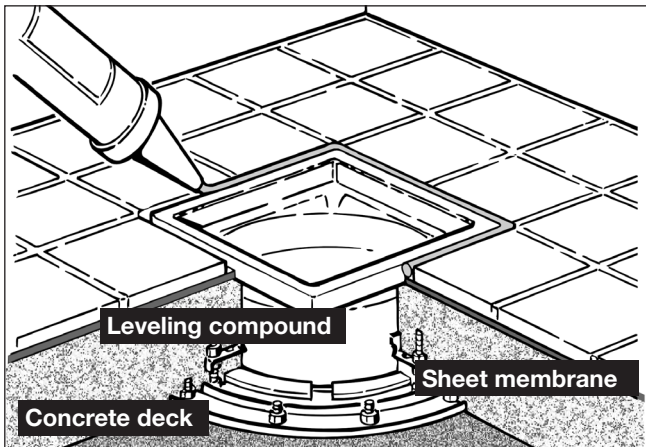

With elastomeric flange

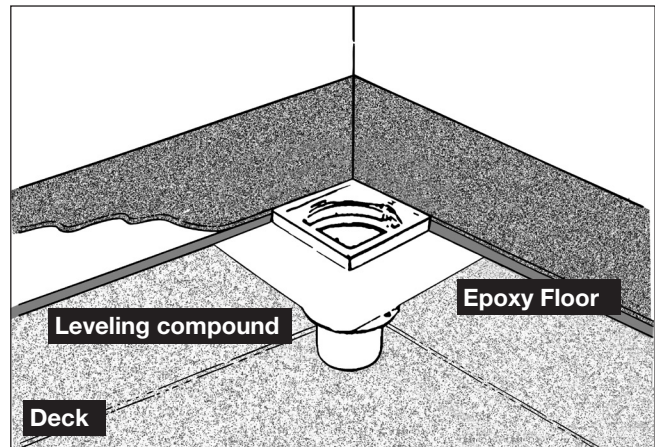

Series BSS Washroom/Shower Drains with Square Top

BSS-100 Washroom/Shower

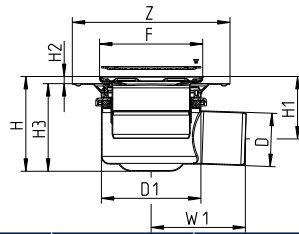

Model No.	Global Part #	Pipe Size D	D1	Top Size F	Z	Adjustable H	Adjustable H1	Adjustable H2	Adjustable H3	W1
BSS-102	312.300.050	2"(50)	5-1/2"(140)	6"x6"(145x145)	8-3/4"(222)	5-1/4"(133) 7-3/8"(188)	3-9/16"(90) 4-3/16"(105)	7/16"(10) 2"(50)	4-7/8"(123) 5-7/16"(138)	5-1/4"(133)
BSS-103	312.300.075	3"(75)	5-1/2"(140)	6"x6"(145x145)	8-3/4"(222)	5-1/4"(133) 7-3/8"(188)	3-1/2"(88) 5-11/16"(143)	7/16"(10) 2"(50)	4-7/8"(123) 5-7/16"(138)	5-1/4"(133)

BSS-300 Washroom/Shower

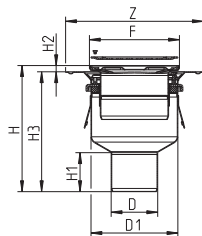

Model No.	Global Part #	Pipe Size D	D1	Top Size F	Z	Adjustable H	H1	Adjustable H2	Adjustable H3
BSS-302	352.300.050	2"(50)	5-1/2"(140)	6"x6"(145x145)	8-3/4"(222)	8-1/8"(207) 10-1/4"(261)	2-5/16"(58)	7/16"(10) 2"(50)	7-3/4"(197) 8-3/8"(212)
BSS-303	352.300.075	3"(75)	5-1/2"(140)	6"x6"(145x145)	8-3/4"(222)	8"(203) 10-13/16"(258)	2-1/2"(63)	7/16"(10) 2"(50)	7-5/8"(193) 8-3/16"(208)
BSS-304	352.300.110	4"(110)	5-1/2"(140)	6"x6"(145x145)	8-3/4"(222)	6-3/4"(171) 8-7/8"(226)	3-1/8"(79)	7/16"(10) 2"(50)	6-5/16"(161) 6-15/16"(176)

Series BSS Optional Gratings		No additional charge	
	-A	Athens	
	-C	Copenhagen	
	-D	Detroit	
	-N	New York	
	-O	Oslo	

Series BSR Washroom/Shower Drains w/Surface Membrane Clamp

BSR-700 Washroom/Shower

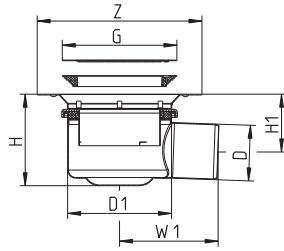

Model No.	Global Part #	Pipe Size D	D1	Top Size Z	G	H Adjustable	H1 Adjustable	W1
BSR-702	210.300.050	2"(50)	5-1/2"(140)	8-3/4"(222)	6-1/8"(155)	4-3/4"(120) - 5-1/8"(130)	2-3/8"(60) - 2-13/16"(70)	5"(127)
BSR-703	210.300.075	3"(75)	5-1/2"(140)	8-3/4"(222)	6-1/8"(155)	4-7/8"(123) - 6-1/16"(153)	3-1/8"(78) - 4-5/16"(108)	5-1/4"(133)

BSR-800 Washroom/Shower

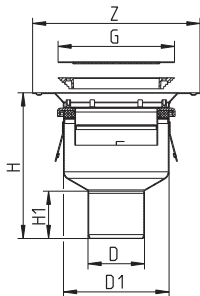

Model No.	Global Part #	Pipe Size D	D1	Top Size Z	G	H Adjustable	H1
BSR-802	250.300.050	2"(50)	5-1/2"(140)	8-3/4"(222)	6-1/8"(155)	7-3/4"(197) - 8-15/16"(227)	2-5/16"(58)
BSR-803	250.300.075	3"(75)	5-1/2"(140)	8-3/4"(222)	6-1/8"(155)	7-5/8"(193) - 8-3/4"(223)	2-1/2"(63)
BSR-804	250.300.110	4"(110)	5-1/2"(140)	8-3/4"(222)	6-1/8"(155)	6-5/16"(161) - 7-3/4"(191)	3-1/8"(79)

Series BSR Optional Gratings

-C

Copenhagen

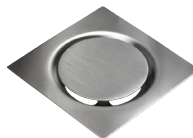
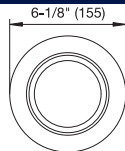

Series BFD Adjustable Floor Drains

BFD-110 Adjustable Floor Drain w/8"x8" Square Top, Membrane Clamp, Bottom Outlet

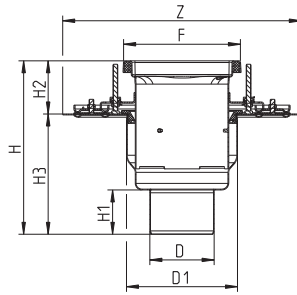

BFD-110-R

Model No.	Global Part #	Pipe Size D	D1	Top Size F	Z	H Adjustable	H1	H2 Adjustable	H3
BFD-113	775.402.075	3"(75)	7-1/2"(190)	8"x8"(200x200)	16-1/8"(409)	11-1/4"(286)-13-5/8"(346)	2-9/16"(65)	3-5/8"(91)-6"(151)	7-11/16"(195)
BFD-114	775.402.110	4"(110)	7-1/2"(190)	8"x8"(200x200)	16-1/8"(409)	11-11/16"(297)-14-1/16"(357)	3"(76)	3-5/8"(91)-6"(151)	8-1/8"(206)

BFD-110-SO Adjustable Floor Drain w/8"x8" Square Top, Membrane Clamp, Side Outlet

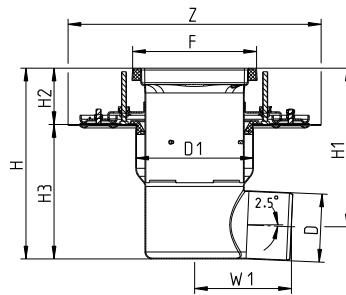

BFD-110-R-SO

Model No.	Global Part #	Pipe Size D	D1	Top Size F	Z	H Adj.	H1 Adj.	H2 Adj.	H3	W1
BFD-113-SO	771.402.075	3"(75)	7-1/2"(190)	8"x8" (200x200)	16-1/8"(409)	12-1/8"(308)-14-1/2"(368)	10-13/16"(275)-13-3/16"(335)	3-5/8"(91)-6"(151)	8-9/16"(217)	9-15/16"(253)
BFD-114-SO	771.402.110	4"(110)	7-1/2"(190)	8"x8" (200x200)	16-1/8"(409)	12-1/8"(308)-14-1/2"(368)	10-1/16"(256)-12-7/16"(316)	3-5/8"(91)-6"(151)	8-9/16"(217)	6-3/16"(156)

Series BFD Adjustable Floor Drains

BFD-130 Adjustable Floor Drain w/12"x12" Square Top, Membrane Clamp, Bottom Outlet

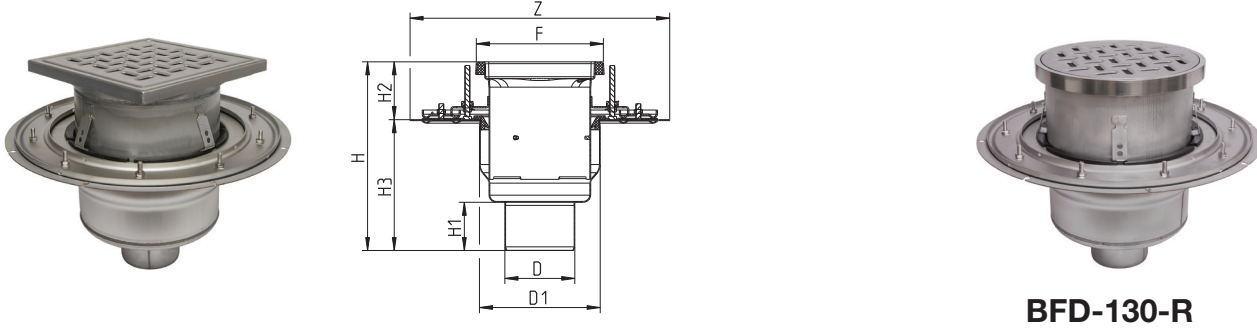

BFD-130-R

Model No.	Global Part #	Pipe Size D	D1	Top Size F	Z	H Adjustable	H1	H2 Adjustable	H3
BFD-134	775.403.110	4"(110)	11-1/2"(291)	12"x12" (300x300)	20"(507)	13-7/16"(342)- 15-13/16"(402)	3"(76)	3-5/8"(91)-6"(151)	9-7/8"(251)
BFD-136	775.403.160	6"(160)	11-1/2"(291)	12"x12" (300x300)	20"(507)	11-11/16"(297)-14- 1/16"(357)	3-3/4"(95)	3-5/8"(91)-6"(151)	10- 5/8"(270)

BFD-130-SO Adjustable Floor Drain w/12"x12" Square Top, Membrane Clamp, Side Outlet

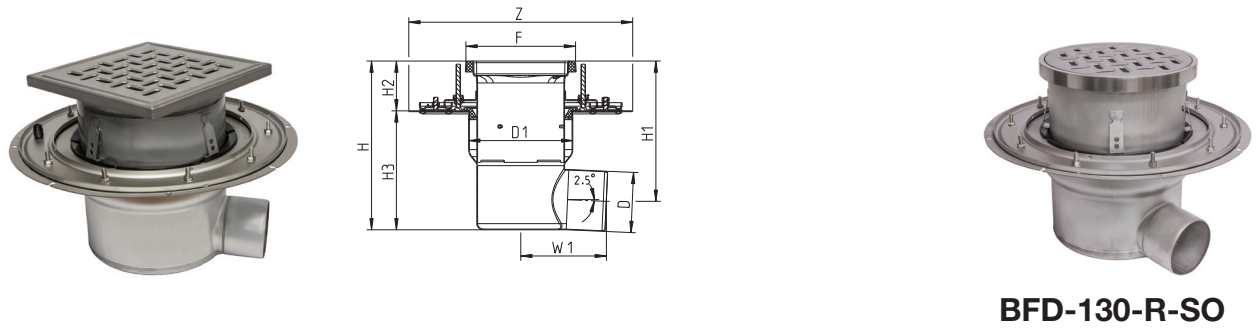

BFD-130-R-SO

Model No.	Global Part #	Pipe Size D	D1	Top Size F	Z	H Adj.	H1 Adj.	H2 Adj.	H3	W1
BFD-134-SO	771.403.110	4"(110)	11- 1/2"(291)	12"x12" (300x300)	20"(507)	12-5/16"(313) 14-11/16"(373)	10-1/4"(261) 12-5/8"(321)	3-5/8"(91) 6"(151)	8-3/4"(222)	8-1/8"(206)
BFD-136-SO	771.403.160	6"(160)	11- 1/2"(291)	12"x12" (300x300)	20"(507)	12-5/16"(313) 14-11/16"(373)	9-5/8"(245) 13-11/16"(348)	3-5/8"(91) 6"(151)	8-3/4"(222)	13-7/16"(341)

Series BFD Options (See p.54)	
Suffix	Description
-316	Type 316 Stainless Steel
-B	Sediment Basket
-P	Stainless Steel P-Trap
-R	Round Top
-SB	Sand Bucket
-TPT	Trap Primer Tapping
-VP	Grate Secured w/Vandal Proof Screws

Series BFD Grating Options (See p. 52-53)	
Suffix	Description
None	1/8" Grating
-150	1/2" Grate (Standard Grating)
-175	3/4" Grate (Standard Grating)
-HG	Hygienic-Pro
-LG	Ladder
-MG	Mesh
-SG	Slot

Series BFD On-Grade Adjustable Floor Drains

BFD-210 On-Grade Adjustable Floor Drain w/8"x8" Square Top, Bottom Outlet

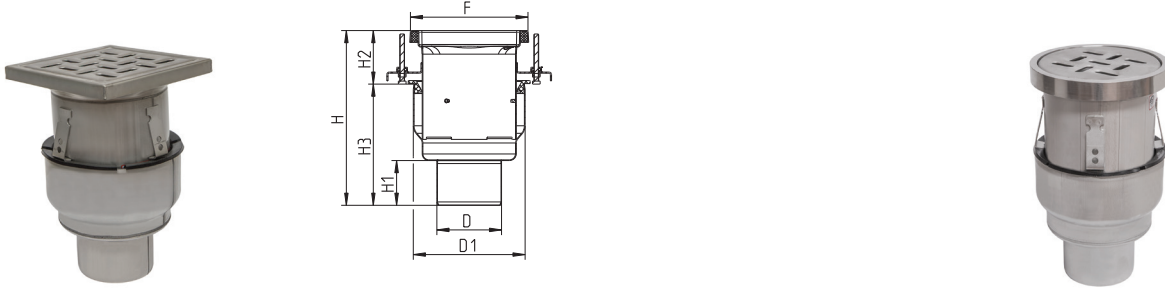

BFD-210-R

Model No.	Global Part #	Pipe Size D	D1	Top Size F	H Adjustable	H1	H2 Adjustable	H3
BFD-213	740.402.075	3"(75)	7-1/2"(190)	8"x8" (200x200)	11-1/4"(286)- 13-5/8"(346)	2-9/16"(65)	3-5/8"(91)-6"(151)	7-11/16"(195)
BFD-214	740.402.110	4"(110)	7-1/2"(190)	8"x8" (200x200)	11-11/16"(297)-14- 1/16"(357)	3"(76)	3-5/8"(91)-6"(151)	8-1/8"(206)

BFD-210-SO On-Grade Adjustable Floor Drain w/8"x8" Square Top, Side Outlet

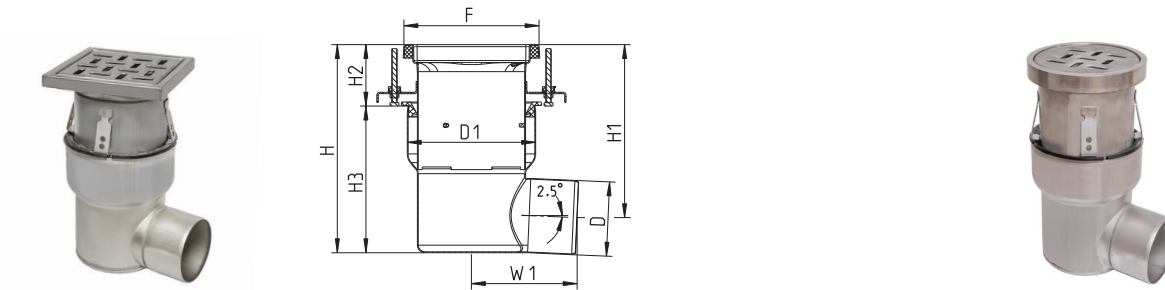

BFD-210-R-SO

Model No.	Global Part #	Pipe Size D	D1	Top Size F	H Adj.	H1 Adj.	H2 Adj.	H3	W1
BFD-213-SO	743.402.075	3"(76)	7-1/2"(190)	8"x8" (200x200)	12-1/8"(308) 14-1/2"(368)	10-13/16"(275) 13-3/16"(335)	3-5/8"(91) 6"(151)	8-9/16"(217)	9-15/16"(253)
BFD-214-SO	743.402.110	4"(110)	7-1/2"(190)	8"x8" (200x200)	12-1/8"(308) 14-1/2"(368)	10-1/16"(256) 12-7/16"(316)	3-5/8"(91) 6"(151)	8-9/16"(217)	6-3/16"(156)

Series BFD On-Grade Adjustable Floor Drains

BFD-230 On-Grade Adjustable Floor Drain w/12"x12" Square Top, Bottom Outlet

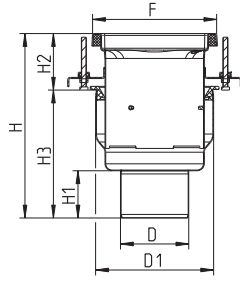

BFD-230-R

Model No.	Global Part #	Pipe Size D	D1	Top Size F	H Adjustable	H1	H2 Adjustable	H3
BFD-234	740.403.110	4"(110)	11-1/2"(291)	12"x12" (300x300)	13-7/16"(342)- 15-13/16"(402)	3"(76)	3-5/8"(91) 6"(151)	9-7/8"(251)
BFD-236	740.403.160	6"(160)	11-1/2"(291)	12"x12" (300x300)	14-3/16"(361) 16-9/16"(421)	3-3/4"(95)	3-5/8"(91) 6"(151)	10-5/8"(270)

BFD-230-SO On-Grade Adjustable Floor Drain w/12"x12" Square Top, Side Outlet

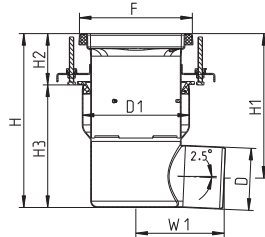

BFD-230-R-SO

Model No.	Global Part #	Pipe Size D	D1	Top Size F	H Adjustable	H1	H2 Adjustable	H3	W1
BFD-234-SO	743.403.110	4"(110)	11-1/2"(291)	12"x12" (300x300)	12-5/16"(313) 14-11/16"(373)	10-1/4"(261) 12-5/8"(321)	3-5/8"(91) 6"(151)	8-3/4"(222)	8-1/8"(206)
BFD-236-SO	743.403.160	6"(160)	11-1/2"(291)	12"x12" (300x300)	12-5/16"(313) 14-11/16"(373)	9-5/8"(245) 13-11/16"(348)	3-5/8"(91) 6"(151)	8-3/4"(222)	13-7/16"(341)

Series BFD Options (See p.54)	
Suffix	Description
-316	Type 316 Stainless Steel
-B	Sediment Basket
-P	Stainless Steel P-Trap
-R	Round Top
-SB	Sand Bucket
-TPT	Trap Primer Tapping
-VP	Grate Secured w/Vandal Proof Screws

Series BFD Grating Options (See p.52-53)	
Suffix	Description
None	1/8" Grating
-150	1/2" Grate (Standard Grating)
-175	3/4" Grate (Standard Grating)
-HG	Hygienic-Pro
-LG	Ladder
-MG	Mesh
-SG	Slot

Series BFD Sanitary Floor Drains with Square Top

BFD-320 Sanitary Floor Drain w/8"x8" Square Top, Bottom Outlet

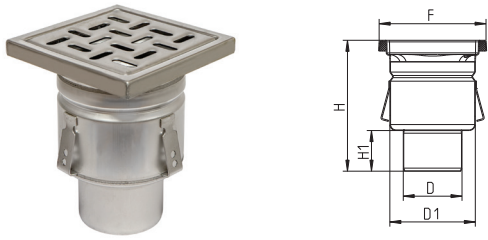

Model No.	Global Part #	Pipe Size D	D1	Top Size F	H	H1
BFD-323	766.402.075	3"(75)	6"(160)	8"x8"(200x200)	9-3/16"(234)	2-9/16"(65)
BFD-324	766.402.110	4"(110)	6"(160)	8"x8"(200x200)	9-1/4"(235)	3"(76)

BFD-320-SO Sanitary Floor Drain w/8"x8" Square Top, Side Outlet

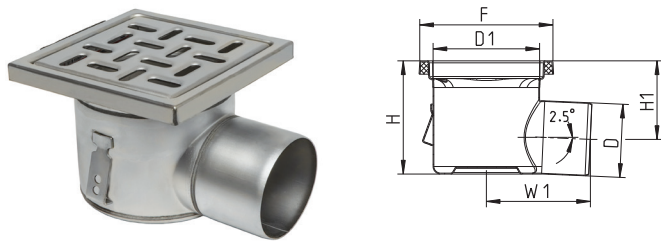

Model No.	Global Part #	Pipe Size D	D1	Top Size F	H	H1	W1
BFD-323-SO	726.402.075	3"(75)	6"(160)	8"x8"(200x200)	6-11/16"(170)	5-7/16"(137)	9-15/16"(253)
BFD-324-SO	726.402.110	4"(110)	6"(160)	8"x8"(200x200)	6-11/16"(170)	4-11/16"(118)	6-3/16"(156)

Series BFD Sanitary Floor Drains with Square Top

BFD-340 Sanitary Floor Drain w/12"x12" Square Top, Bottom Outlet

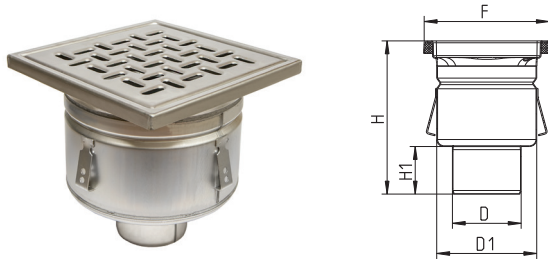

Model No.	Global Part #	Pipe Size D	D1	Top Size F	H	H1
BFD-343	766.403.075	3"(75)	10-1/4"(260)	12"x12"(300x300)	10-3/4"(273)	2-9/16"(65)
BFD-344	766.403.110	4"(110)	10-1/4"(260)	12"x12"(300x300)	11-3/16"(284)	3"(76)
BFD-346	766.403.160	6"(160)	10-1/4"(260)	12"x12"(300x300)	11-15/16"(303)	3-3/4"(95)

BFD-340-SO Sanitary Floor Drain w/12"x12" Square Top, Side Outlet

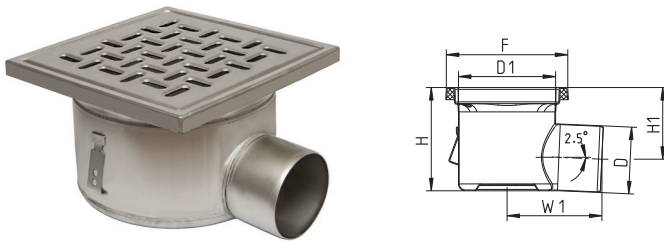

Model No.	Global Part #	Pipe Size D	D1	Top Size F	H	H1	W1
BFD-344-SO	766.403.110	3"(75)	10-1/4"(260)	12"x12"(300x300)	7-3/8"(188)	5-3/8"(136)	8-1/8"(206)
BFD-346-SO	766.403.160	4"(110)	10-1/4"(260)	12"x12"(300x300)	7-3/8"(188)	4-3/4"(120)	13-7/16"(341)

Series BFD Options (See p. 54)

Suffix	Description
-316	Type 316 Stainless Steel
-B	Sediment Basket
-P	Stainless Steel P-Trap
-SB	Sand Bucket
-TPT	Trap Primer Tapping
-VP	Grate Secured w/Vandal Proof Screws

Series BFD Grating Options (See p. 52-53)

Suffix	Description
None	1/8" Grating
-150	1/2" Grate (Standard Grating)
-175	3/4" Grate (Standard Grating)
-HG	Hygienic-Pro
-LG	Ladder
-MG	Mesh
-SG	Slot

Series BFD Sanitary Floor Drains with Round Top

BFD-420 Sanitary Floor Drain w/8" Round Top, Bottom Outlet

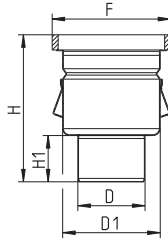

<i>Model No.</i>	<i>Global Part #</i>	<i>Pipe Size D</i>	<i>D1</i>	<i>Top Size F</i>	<i>H</i>	<i>H1</i>
BFD-423	766.502.075	3"(75)	6"(160)	7-5/8"(195)	9-1/16"(230)	2-9/16"(65)
BFD-424	766.502.110	4"(110)	6"(160)	7-5/8"(195)	9-1/2"(241)	3"(76)

BFD-420-SO Sanitary Floor Drain w/8" Round Top, Side Outlet

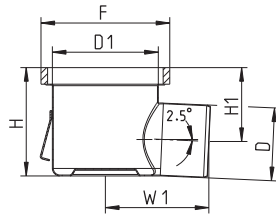

<i>Model No.</i>	<i>Global Part #</i>	<i>Pipe Size D</i>	<i>D1</i>	<i>Top Size F</i>	<i>H</i>	<i>H1</i>	<i>W1</i>
BFD-423-SO	726.502.075	3"(75)	6"(160)	7-5/8"(195)	6-7/16"(164)	5"(127)	9-15/16"(253)
BFD-424-SO	726.502.110	4"(110)	6"(160)	7-5/8"(195)	6-7/16"(164)	4-7/16"(112)	6-3/16"(156)

Series BFD Sanitary Floor Drains with Round Top

BFD-440 Sanitary Floor Drain w/12" Round Top, Bottom Outlet

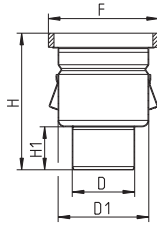

Model No.	Global Part #	Pipe Size D	D1	Top Size F	H	H1
BFD-443	766.503.075	3"(75)	10-1/4"(260)	11-5/8"(295)	10-9/16"(268)	2-9/16"(65)
BFD-444	766.503.110	4"(110)	10-1/4"(260)	11-5/8"(295)	11"(279)	3"(76)
BFD-446	766.503.160	6"(160)	10-1/4"(260)	11-5/8"(295)	11-3/4"(298)	3-3/4"(95)

BFD-440-SO Sanitary Floor Drain w/12" Round Top, Side Outlet

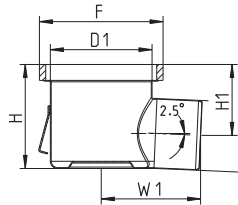

Model No.	Global Part #	Pipe Size D	D1	Top Size F	H	H1	W1
BFD-444-SO	726.503.110	4"(110)	10-1/4"(260)	11-5/8"(295)	9"(228)	6-15/16"(176)	8-1/8"(206)
BFD-446-SO	726.503.160	6"(160)	10-1/4"(260)	11-5/8"(295)	9"(228)	6-5/16"(160)	13-7/16"(341)

Series BFD Options (See p. 54)

Suffix	Description
-316	Type 316 Stainless Steel
-B	Sediment Basket
-P	Stainless Steel P-Trap
-SB	Sand Bucket
-TPT	Trap Primer Tapping
-VP	Grate Secured w/Vandal Proof Screws

Series BFD Grating Options (See p. 52-53)

Suffix	Description
None	1/8" Grating
-150	1/2" Grate (Standard Grating)
-175	3/4" Grate (Standard Grating)
-HG	Hygienic-Pro
-LG	Ladder
-MG	Mesh
-SG	Slot

Series BFD Floor Drains with Surface Membrane Clamp

BFD-510 Floor Drain w/8" Round Top, Surface Membrane Clamp, Bottom Outlet (For Sheet Flooring)

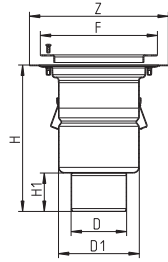

Model No.	Global Part #	Pipe Size D	D1	Top Size F	Z	H	H1
BFD-513	760.602.075	3"(75)	6"(160)	9-1/8"(232)	10-13/16"(275)	11"(279)	2-9/16"(65)
BFD-514	760.602.110	4"(110)	6"(160)	9-1/8"(232)	10-13/16"(275)	11-7/16"(290)	3"(76)

BFD-510-SO Floor Drain w/8" Round Top, Surface Membrane Clamp, Side Outlet (For Sheet Flooring)

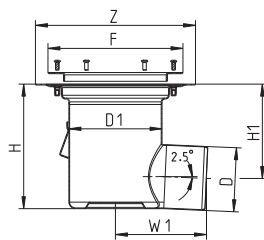

Model No.	Global Part #	Pipe Size D	D1	Top Size F	Z	H	H1	W1
BFD-513-SO	763.602.075	3"(75)	6"(160)	9-1/8"(232)	10-13/16"(275)	8-7/16"(214)	7-1/8"(181)	9-15/16"(253)
BFD-514-SO	763.602.110	4"(110)	6"(160)	9-1/8"(232)	10-13/16"(275)	8-7/16"(214)	6-3/8"(162)	6-3/16"(156)

Series BFD Floor Drains with Surface Membrane Clamp

BFD-530 Floor Drain w/12" Round Top, Surface Membrane Clamp, Bottom Outlet (For Sheet Flooring)

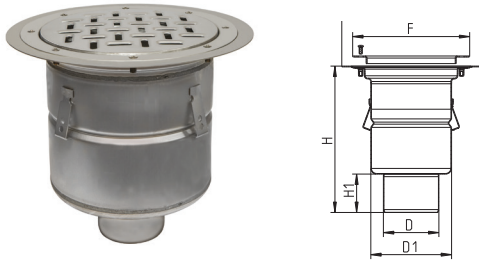

Model No.	Global Part #	Pipe Size D	D1	Top Size F	Z	H	H1
BFD-534	760.603.110	4"(110)	10-1/4"(260)	13"(332)	14-3/4"(375)	13-1/4"(336)	3"(76)
BFD-536	760.603.160	6"(160)	10-1/4"(260)	13"(332)	14-3/4"(375)	14"(355)	3-3/4"(95)

BFD-530-SO Floor Drain w/12" Round Top, Surface Membrane Clamp, Side Outlet (For Sheet Flooring)

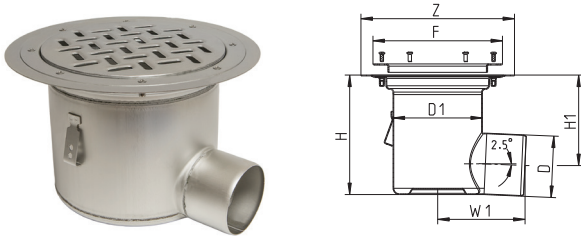

Model No.	Global Part #	Pipe Size D	D1	Top Size F	Z	H	H1	W1
BFD-534-SO	763.603.110	4"(110)	10-1/4"(260)	13"(332)	14-3/4"(375)	9-7/16"(240)	7-3/8"(188)	8-1/8"(206)
BFD-536-SO	763.603.160	6"(160)	10-1/4"(260)	13"(332)	14-3/4"(375)	9-7/16"(240)	6-3/4"(172)	13-7/16"(341)

Series BFD Sanitary Floor Drains with Elastomeric Flange

BFD-550 Sanitary Floor Drain w/8"x8" Square Top, Elastomeric Flange

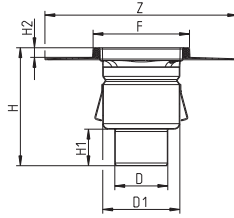

Model No.	Global Part #	Pipe Size D	D1	Top Size F	Z	H	H1	H2
BFD-553	767.402.075	3"(75)	6"(160)	8"x8"(200x200)	15-3/4"x15-3/4" (400x400)	9-3/16"(234)	2-9/16"(65)	13/16"(20)
BFD-554	767.402.110	4"(110)	6"(160)	8"x8"(200x200)	15-3/4"x15-3/4" (400x400)	9-5/8"(245)	3"(76)	13/16"(20)

BFD-560 Sanitary Floor Drain w/12"x 12" Square Top, Elastomeric Flange

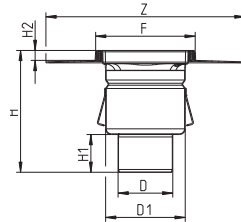

Model No.	Global Part #	Pipe Size D	D1	Top Size F	Z	H	H1	H2
BFD-563	767.403.075	3"(75)	10-1/4"(260)	12"x12"(300x300)	19-3/4"x19-3/4" (500x500)	10-3/4"(273)	2-9/16"(65)	13/16"(20)
BFD-564	767.403.110	4"(110)	10-1/4"(260)	12"x12"(300x300)	19-3/4"x19-3/4" (500x500)	11-3/16"(284)	3"(76)	13/16"(20)
BFD-566	767.403.160	6"(160)	10-1/4"(260)	12"x12"(300x300)	19-3/4"x19-3/4" (500x500)	11-15/16"(303)	3-3/4"(95)	13/16"(20)

Series BFD Options (See p. 54)

Suffix	Description
-316	Type 316 Stainless Steel
-B	Sediment Basket
-P	Stainless Steel P-Trap
-SB	Sand Bucket
-TPT	Trap Primer Tapping
-VP	Grate Secured w/Vandal Proof Screws

Series BFD Grating Options (See p. 52-53)

Suffix	Description
None	1/8" Grating
-150	1/2 Grate (Standard Grating)
-175	3/4 Grate (Standard Grating)
-HG	Hygienic-Pro
-LG	Ladder
-MG	Mesh
-SG	Slot

HygienicPro® Floor Drains

BFD-570 HygienicPro® Floor Drain w/12" Round Top

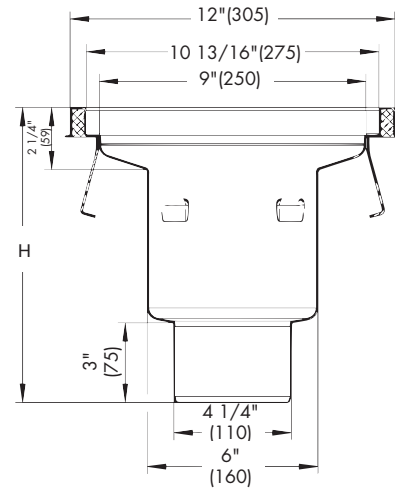

Model No.	Global Part #	Pipe Size D	H
BFD-574L	755.513.110	4"(110)	10 7/8"(277)
BFD-574M	755.503.110	4"(110)	14 7/8"(378)
BFD-574H	755.573.110	4"(110)	17 15/16"(455)

BFD-570-SO HygienicPro® Floor Drain w/12" Round Top, Side Outlet

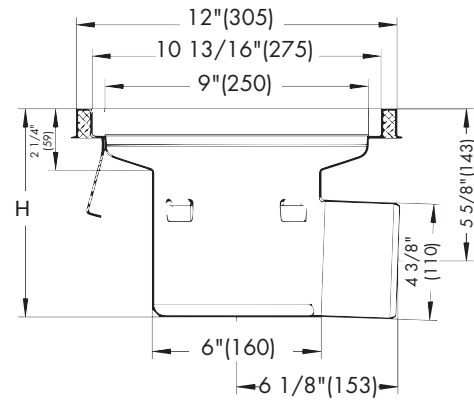

Model No.	Global Part #	Pipe Size D	H
BFD-574L-SO	756.513.110	4"(110)	7 13/16"(198)
BFD-574M-SO	756.503.110	4"(110)	11 3/4"(299)
BFD-574H-SO	756.573.110	4"(110)	14 13/16"(376)

Series BFD Options (See p. 54)

Suffix	Description
-316	Type 316 Stainless Steel
-B	Sediment Basket
-P	Stainless Steel P-Trap

Series BFD Gastight Industrial Drains

BFD-610 Gastight Industrial Drain with Square Top

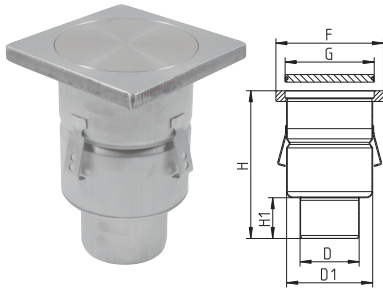

Model No.	Global Part #	Pipe Size D	D1	Top Size F	G	H	H1
BFD-613	760.452.075S	3"(75)	6"(160)	8"x8"(200x200)	6-1/2"(166)	10-13/16"(275)	3"(76)
BFD-614	760.452.110S	4"(110)	6"(160)	8"x8"(200x200)	6-1/2"(166)	10-13/16"(275)	3"(76)

BFD-610-R Gastight Industrial Drain with Round Top

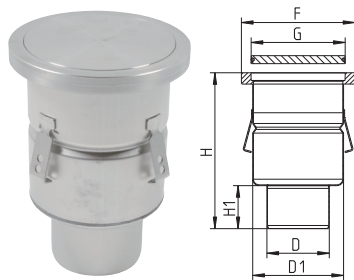

Model No.	Global Part #	Pipe Size D	D1	Top Size F	G	H	H1
BFD-613-R	760.552.075S	3"(75)	6"(160)	8"dia.(200)	6-1/2"(166)	10-13/16"(275)	3"(76)
BFD-614-R	760.552.110S	4"(110)	6"(160)	8"dia.(200)	6-1/2"(166)	10-13/16"(275)	3"(76)

Series BFD Options (See p. 54)

Suffix	Description
-316	Type 316 Stainless Steel
-B	Sediment Basket
-P	Stainless Steel P-Trap
-TPT	Trap Primer Tapping

Vacuum Handles



Model No.	Global Part #	Size
BFD-VH4	700.000.002	4"(110)
BFD-VH6	700.000.003	6"(160)

Series BFD Hub Drains/Trap Primer Adaptors

BHD-100 Hub Drain

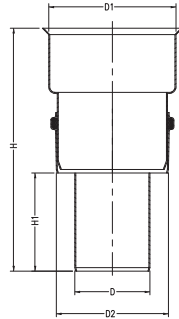

Model No.	Global Part #	Pipe Size D	D1	D2	H	H1
BHD-102	N/A	2"(50)	5"(127)	4-3/8"(111)	9-3/8"(239)	3-3/4"(94)
BHD-103	N/A	3"(75)	5"(127)	4-3/8"(111)	9-9/16"(243)	3-7/8"(98)
BHD-104	N/A	4"(110)	5"(127)	4-3/8"(111)	11-9/16"(295)	5-7/8"(150)
BHD-106	N/A	6"(160)	8"(200)	6"(160)	13-1/16"(332)	5-7/8"(150)

BTPC Trap Primer Adaptor

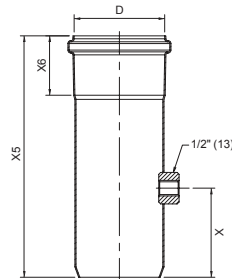

Model No.	Global Part #	D	X	X5	X6
BTPC-2-316	899-12911-07S	2"(50)	3"(75)	8"(200)	1-5/8"(41)
BTPC-3-316	899-12911-08S	3"(75)	3"(75)	8"(200)	2"(50)
BTPC-4-316	899-12911-10S	4"(110)	3"(75)	8"(200)	2-1/4"(57)
BTPC-6-316	899-12911-12S	6"(160)	3"(75)	8"(200)	2-7/8"(72)

Series BFD Square Gratings

Commercial/Industrial Square Gratings

1/8" Standard Grating

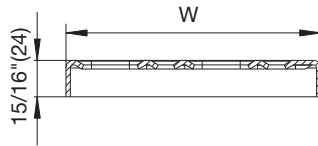

Hygienic-Pro Grating (-HG)

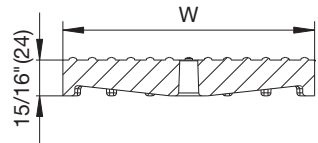

Ladder Grating (-LG)

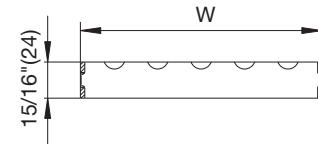

Mesh Grating (-MG)

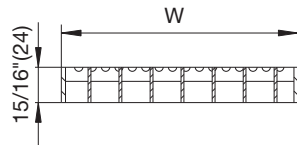
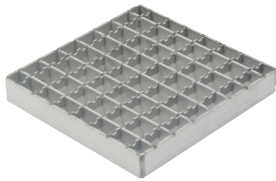

Slot Grating (-SG)

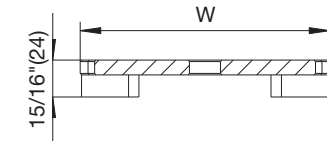

Please see ES-B-Commercial/Industrial Round Gratings for more information.

NOTICE

Load Ratings

Load ratings are based upon maximum anticipated traffic, in accordance with American Standards ASME A112.6.3-2016. See specification pages for specific load rating data.

Product Data

Model No.	Global Part No.	Load Rating ASME A112.6.3-2016	W	Free Area Sq. In.
1/8 Standard Grating				
BG-8	790.168.000.03	MD	6 5/8"x6 5/8"(168x168)	8.68
BG-12	790.268.000.03	MD	10 5/8"x10 5/8"(270x270)	19.55
Mesh Grating (-MG)				
BMG-8	790.168.000.22	HD	6 5/8"x6 5/8"(168X168)	33.49
BMG-12	790.268.000.22	HD	10 5/8"X10 5/8"(270X270)	85.20
Hygienic-Pro Grating (-HG)				
BHG-8	790.168.000.60	HD	6 5/8"X6 5/8"(168X168)	25.30
BHG-12	790.268.000.60	HD	10 5/8"X10 5/8"(270X270)	61.17
Slot Grating (-SG)				
BSG-8	790.168.000.10	HD	6 5/8"X6 5/8"(168X168)	8.42
BSG-12	790.268.000.10	HD	10 5/8"X10 5/8"(270X270)	16.52
Ladder Grating (-LG)				
BLG-8	790.168.000.25	XHD	6 5/8"x6 5/8"(168x168)	32.94
BLG-12	790.268.000.25	XHD	10 5/8"x10 5/8"(270x270)	83.79

* ASME A112.6.3 data interpolated based on EN 1253 testing results.

Approvals



Compliance with NSF/ANSI/3-A 14159-1-Hygiene Requirements for the Design of Meat and Poultry Processing Equipment



Product is certified to the uniform plumbing code ASME A112.6.3

Series BFD Round Gratings

Commercial/Industrial Round Gratings

1/8" Standard Grating

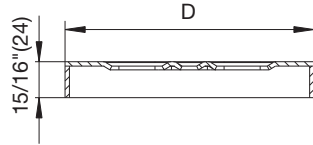

Hygienic-Pro Grating (-HG)

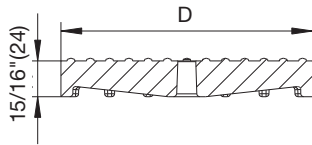
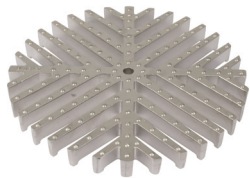

Ladder Grating (-LG)

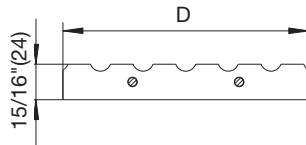

Mesh Grating (-MG)

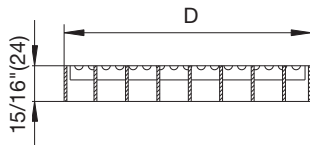
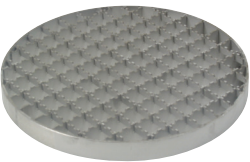

Slot Grating (-SG)

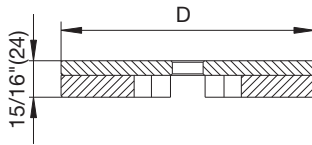
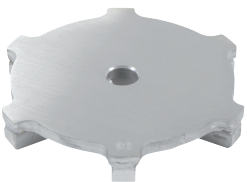

Please see ES-B-Commercial/Industrial Square Gratings for more information.

NOTICE

Load Ratings

Load ratings are based upon maximum anticipated traffic, in accordance with American Standards ASME A112.6.3-2016. See specification pages for specific load rating data.

Product Data

Model No.	Global Part No.	Load Rating ASME A112.6.3-2016	D	Free Area Sq. In.
1/8" Standard Grating				
BG-8R	790.173.000.03	MD	6 13/16"(173)	4.58
BG-12R	790.273.000.03	MD	10 3/4"(273)	16.31
Mesh Grating (-MG)				
BMG-8R	790.173.000.22	HD	6 13/16"(173)	28.88
BMG-12R	790.273.000.22	HD	10 3/4"(273)	72.78
Hygienic-Pro Grating (-HG)				
BHG-8R	790.173.000.60	HD	6 13/16"	23.39
BHG-12R	790.273.000.60	HD	10 3/4"	56.85
Slot Grating (-SG)				
BSG-8R	790.173.000.10	HD	6 13/16"(173)	7.885
BSG-12R	790.273.000.10	HD	10 3/4"(273)	13.85
Ladder Grating (-LG)				
BLG-8R	790.173.000.25	XHD	6 13/16"(173)	26.87
BLG-12R	790.273.000.25	XHD	10 3/4"(273)	68.41

* ASME A112.6.3 data interpolated based on EN 1253 testing results.

Approvals



Compliance with NSF/ANSI/3-A 14159-1-Hygiene Requirements for the Design of Meat and Poultry Processing Equipment



Product is certified to the uniform plumbing code ASME A112.6.3

Series BFD Options

Options

Sediment Basket (-B)

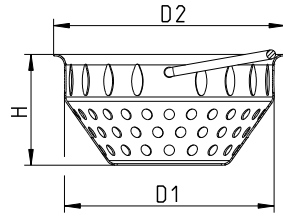

Dimensional Chart

Model No.	Global Part #	D1	H	D2
BB-1	780.107.110.05	3-1/8"(80)	3-1/2"(88)	4-1/4"(107)
BB-2	780.002.000.05	5-1/2"(140)	2-15/16"(74)	6-1/8"(155)
BB-3	780.003.000.05	9-3/8"(238)	2-15/16"(74)	10"(253)
BB-4	780.002.001.05	5-1/2"(140)	7/8"(22)	6"(150)
BB-5	780.003.001.05	9-3/8"(238)	5/8"(16)	10"(249)

Sand Bucket (-SB)

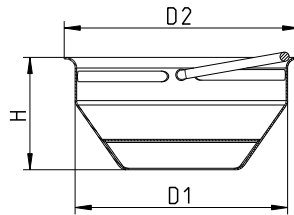

Dimensional Chart

Model No.	Global Part #	D1	H	D2
BSB-1	780.002.000.00	5-1/2"(140)	2-15/16"(74)	6-1/8"(155)
BSB-2	780.003.000.00	9-3/8"(238)	2-15/16"(74)	10"(253)

P-Trap Stainless Steel (-P)

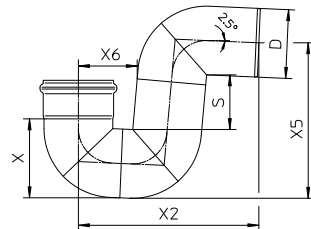

Dimensional Chart

Model No.	Global Part #	D	S	X	X2	X5	X6
PT-2	525.090.050S	2"(50)	2-15/16"(74)	2-1/2"(63)	6-7/8"(175)	5-3/4"(145)	2-3/8"(60)
PT-3	525.090.075S	3"(75)	3-1/4"(81)	3-9/16"(89)	8-3/4"(222)	7-7/16"(189)	2-15/16"(74)
PT-4	525.090.110S	4"(110)	3-9/16"(89)	5"(126)	11-3/8"(289)	9-13/16"(249)	3-3/4"(94)
PT-6	525.090.160S	6"(160)	4-3/16"(105)	7"(178)	15-1/4"(388)	13-5/16"(338)	4-13/16"(121)

Transition Couplings

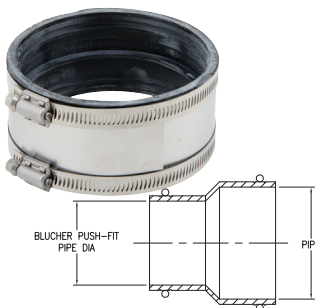

Transition Couplings

Model No. 316L	Global Part #	BLÜCHER	Cast Iron	Sch40
BTC-2x2	N/A	2"(50)	2"	2"
BTC-3x3-NH	N/A	3"(75)	3"	
BTC-3x3-SCH40	N/A	3"(75)		3"
BTC-4x4-NH	N/A	4"(110)	4"	
BTC-4x4-SCH40	N/A	4"(110)		4"
BTC-6x6-NH	N/A	6"(160)	6"	
BTC-6x6-SCH40	N/A	6"(160)		6"

Series BCO Floor Cleanouts

BCO-110 Floor Cleanout w/Square Top, Pull Nipple

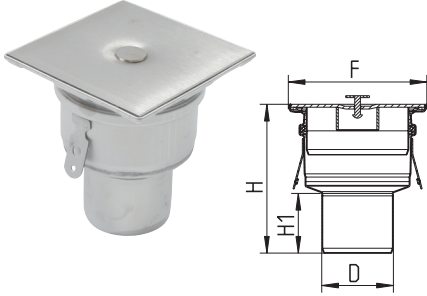

Model No.	Global Part #	Pipe Size D	Top Size F	H	H1
BCO-113	144.150.075	3"(75)	5-3/4"x5-3/4"(145x145)	6-3/16"(156)	2-1/2"(63)
BCO-114	144.150.110	4"(110)	5-3/4"x5-3/4"(145x145)	4-3/4"(120)	-
BCO-116	144.200.160	6"(160)	8"x8"(200x200)	6-1/4"(159)	-

BCO-120 Floor Cleanout w/Square Top for Vacuum Handle

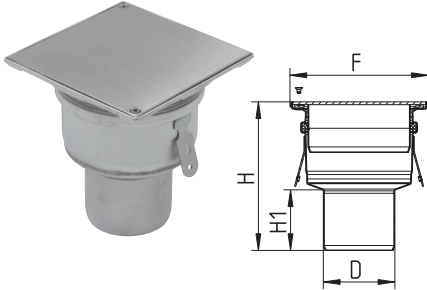

Model No.	Global Part #	Pipe Size D	Top Size F	H	H1
BCO-123	144.155.075	3"(75)	5-3/4"x5-3/4"(145x145)	6-3/16"(156)	2-1/2"(63)
BCO-124	144.155.110	4"(110)	5-3/4"x5-3/4"(145x145)	4-3/4"(120)	-
BCO-126	144.205.160	6"(160)	8"x8"(200x200)	6-1/4"(159)	-

BCO-130 Heavy Duty Floor Cleanout w/Square Top for Vacuum Handle

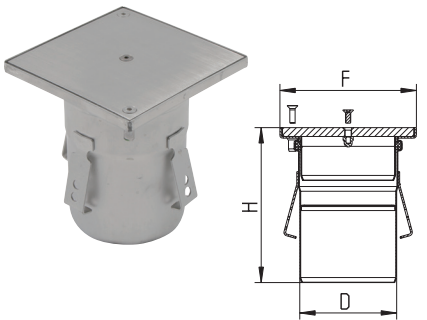

Model No.	Global Part #	Pipe Size D	Top Size F	H
BCO-134	144.155.110.10	4"(110)	6-1/8"x 6-1/8"(155x155)	6-15/16"(176)
BCO-136	144.205.160.10	6"(160)	8"x 8"(200x200)	6-5/16"(160)

BCO-140 Floor Cleanout w/Round Top, Pull Nipple

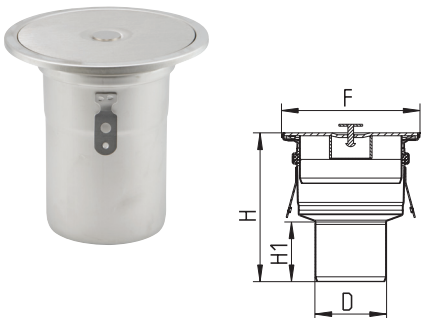

Model No.	Global Part #	Pipe Size D	Top Size F	H	H1
BCO-143	S199-13488-04-S	3"(75)	7-1/8"(180)	6"(151)	2-1/2"(63)
BCO-144	S199-13488-01-S	4"(110)	7-1/8"(180)	7-1/8"(181)	-

Series BCO Floor Cleanouts

BCO-150 Heavy Duty Floor Cleanout w/Round Top for Vacuum Handle

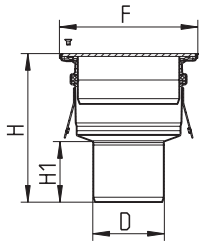

Model No.	Global Part #	Pipe Size D	Top Size F	H	H1
BCO-153	S199-13488-05-S	3"(75)	7-1/8"(180)	6"(156)	2-1/2"(63)
BCO-154	S199-13488-02-S	4"(110)	7-1/8"(180)	7-1/8"(181)	-

BCO-220 Floor Cleanout w/Surface Membrane Clamp for Vacuum Handle (For Sheet Flooring)

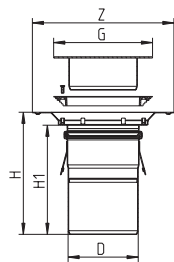

Model No.	Global Part #	Pipe Size D	Top Size Z	G	H	H1
BCO-224	244.155.110	4"(110)	8-3/4"(222)	6-1/8"(155)	7-9/16"(192)	6-3/4"(171)

Series BCO Options

Suffix	Description
-316	Type 316 Stainless Steel

Vacuum Handles



BFD-VH4



BFD-VH6

Model No.	Global Part #	Size
BFD-VH4	700.000.002	4"(110)
BFD-VH6	700.000.003	6"(160)

Installation examples

Tiled deck incl. water trap

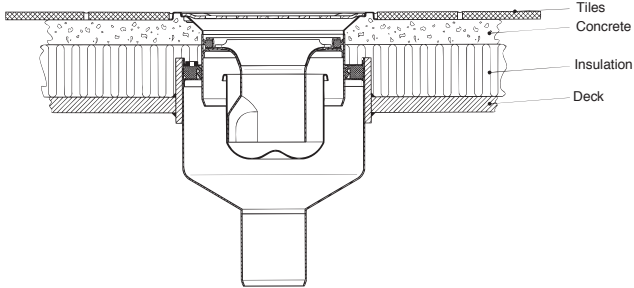

Tiled deck incl. water trap and extension pipe

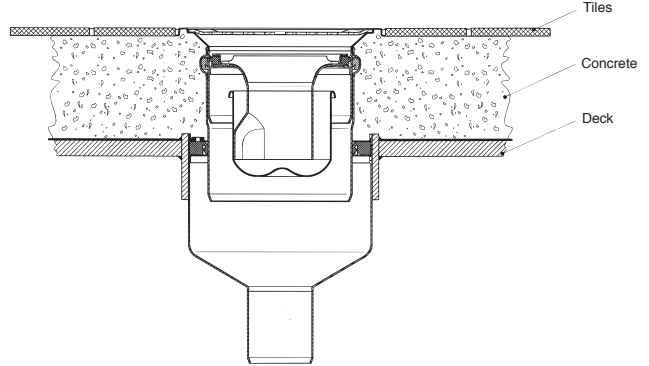

Tiled deck incl. water trap and side inlets

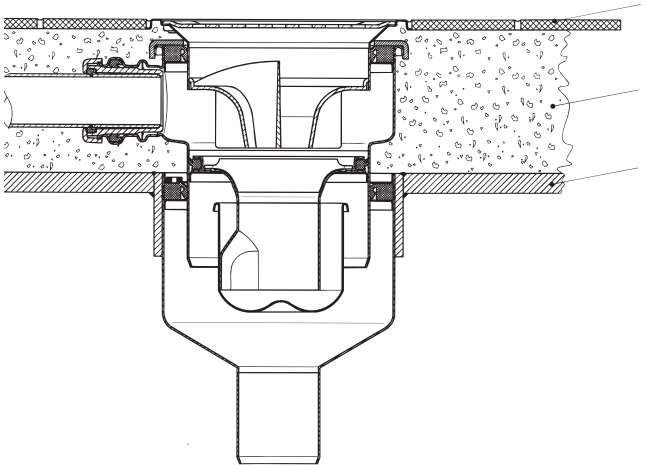

Vinyl deck incl. water trap

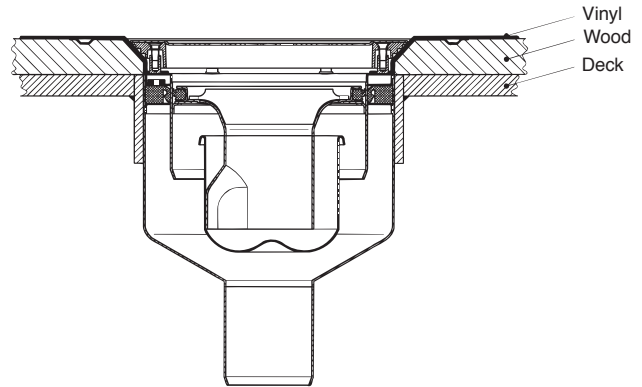

Steel deck

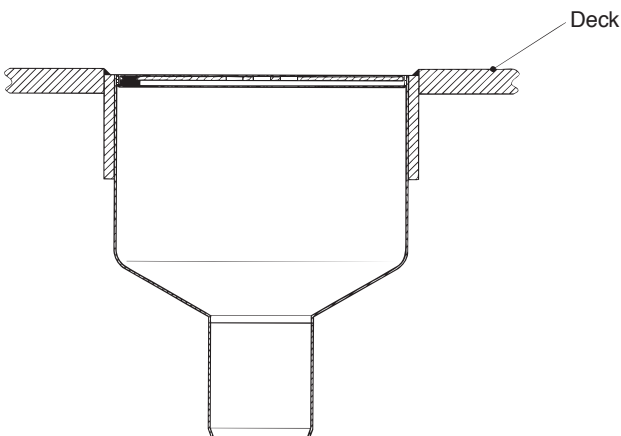

Aluminium deck

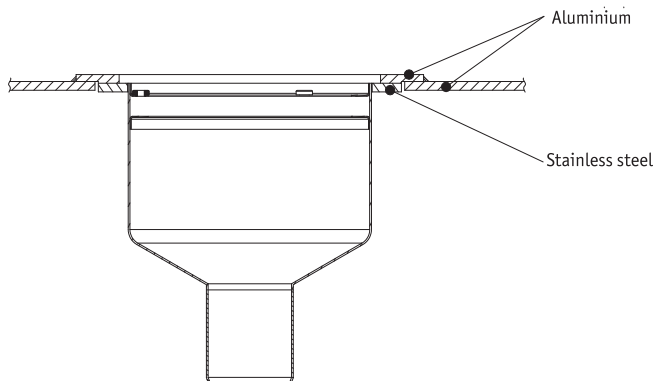

Marine Drains Lower Parts

Lower Part for Steel Deck with Welding Sleeve

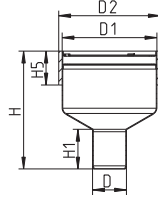

Model No. 316L / Global Part #	Pipe Size D	D1	H	H1	H5	D2
470.000.050S	2"(50)	5-1/2"(140)	6-7/8"(174)	2-1/4"(58)	2"(50)	5-7/8"(150)
470.000.075S	3"(75)	5-1/2"(140)	6-3/4"(172)	2-1/2"(63)	2"(50)	5-7/8"(150)
470.000.110S	4"(110)	5-1/2"(140)	5-3/4"(146)	2-15/16"(75)	2"(50)	5-7/8"(150)

Lower Part for Steel Deck with Welding Flange

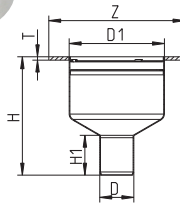

Model No. 316L / Global Part #	Pipe Size D	D1	Z	H	H1	T
470.200.050S	2"(50)	5-1/2"(140)	7-7/8"(200)	6-7/8"(174)	2-1/4"(58)	3/16"(5)
470.200.075S	3"(75)	5-1/2"(140)	7-7/8"(200)	6-3/4"(172)	2-1/2"(63)	3/16"(5)
470.200.110S	4"(110)	5-1/2"(140)	7-7/8"(200)	5-9/16"(141)	2-15/16"(75)	3/16"(5)

Lower Part for Steel Deck with Side Outlet with Welding Sleeve

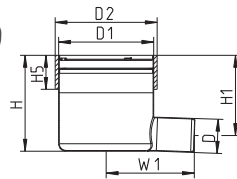

Model No. 316L / Global Part #	Pipe Size D	D1	H	H1	H5	W1	D2
475.000.050S	2"(50)	5-1/2"(140)	5-1/2"(140)	4-5/8"(117)	2"(50)	5-1/16"(129)	5-7/8"(150)
475.000.075S	3"(75)	5-1/2"(140)	5-1/2"(140)	5-1/4"(134)	2"(50)	4-1/8"(105)	5-7/8"(150)

Lower Part for Steel Deck with Deep Side Outlet with Welding Sleeve

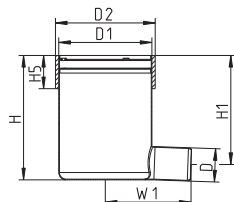

Model No. 316L / Global Part #	Pipe Size D	D1	H	H1	H5	W1	D2
475.100.050S	2"(50)	5-1/2"(140)	7-3/8"(187)	6-7/16"(164)	2"(50)	5-1/16"(129)	5-7/8"(150)

Lower Part for Steel Deck with Side Outlet with Welding Flange

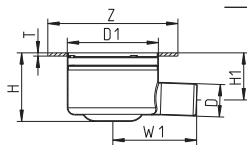

Model No. 316L / Global Part #	Pipe Size D	D1	Z	H	H1	W1	T
475.200.050S	2"(50)	5-1/2"(140)	7-7/8"(200)	4-3/16" (106)	2-13/16" (72)	5-1/16"(129)	3/16"(5)
475.200.075S	3"(75)	5-1/2"(140)	7-7/8"(200)	4-3/16" (106)	2-13/16" (71)	5-1/4"(134)	3/16"(5)

Lower Part for Aluminum Deck with Bi-Metal Welding Flange

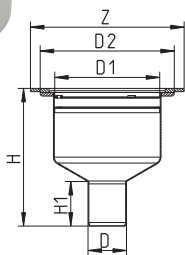

Model No. 316L / Global Part #	Pipe Size D	D1	Z	H	H1	D2
480.200.050S	2"(50)	5-1/2"(140)	7-7/8"(200)	7-1/16"(179)	2-1/4"(58)	6-7/8"(175)
480.200.075S	3"(75)	5-1/2"(140)	7-7/8"(200)	7"(177)	2-1/2"(63)	6-7/8"(175)
480.200.110S	4"(110)	5-1/2"(140)	7-7/8"(200)	5-15/16"(151)	2-15/16"(75)	6-7/8"(175)

Lower Part for Aluminum Deck with Side Outlet with Bi-Metal Welding Flange

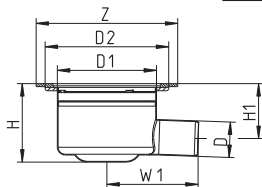

Model No. 316L / Global Part #	Pipe Size D	D1	Z	H	H1	W1	D2
485.200.050S	2"(50)	5-1/2"(140)	7-7/8"(200)	4-3/8"(111)	3-1/16"(78)	5-1/16" (128)	6-7/8" (175)
485.200.075S	3"(75)	5-1/2"(140)	7-7/8"(200)	4-3/8"(111)	3"(76)	5-1/4" (133)	6-7/8" (175)

Marine Drains Upper Parts

Upper Part for Tiled or Wood Floors with Side Inlets

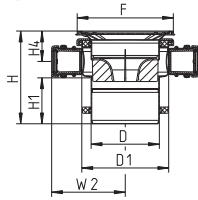
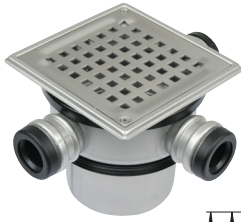

Model No. 316L / Global Part #	Pipe Size D	D1	F	H	H1	H4	W2
471.300.110S	4"(110)	5-1/2" (140)	6-1/8"x6-1/8" (155x155)	5-7/8"-6-15/16" (150-160)	2-7/8" (74)	1-15/16"-2-5/16" (49-59)	4-11/16" (119)

Upper Part for Resin Floors

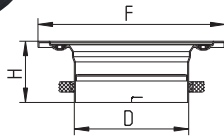

Model No. 316L / Global Part #	Pipe Size D	F	H
472.320.110S	4"(110)	7-1/16"(180)	2-5/16"(59)

Upper Part with Surface Membrane Clamp for Vinyl Floors

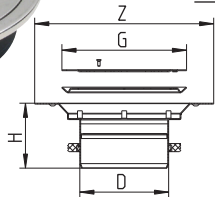

Model No. 316L / Global Part #	Pipe Size D	Z	G	H
473.301.110S	4"(110)	8-3/4"(222)	6-1/8"(155)	3-3/16"(81)

Upper Part with Welding Sleeve for Vinyl Floors

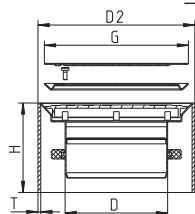

Model No. 316L / Global Part #	Pipe Size D	G	H	D2	T
472.320.110S	4"(110)	6-1/8"(155)	3-3/4"(96)	6-5/8"(168)	1/8"(3)

Marine Drains Replacement Gratings/Water Traps

Replacement Gratings — Square, Round, Round w/Ring for Water Trap

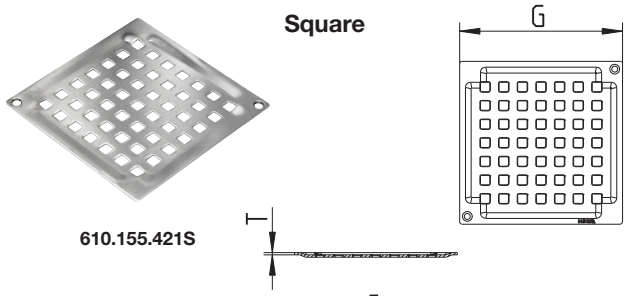

Model No. 316L / Global Part #	Pipe Size G	T	Screws
610.155.421S	5-1/2"(140)	1/16"(2)	2
620.135.021S	5-5/16"(135)	1/16"(2)	3
474.300.110S	5-5/16"(135)	1/16"(2)	3

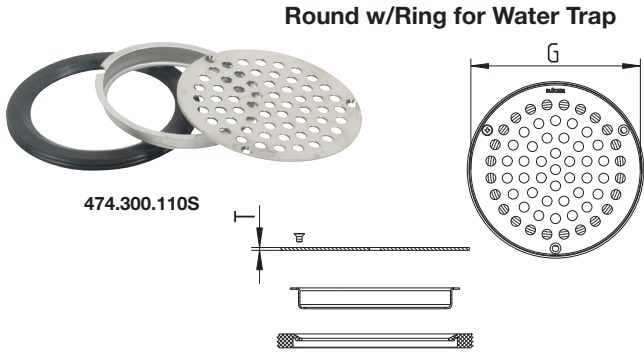
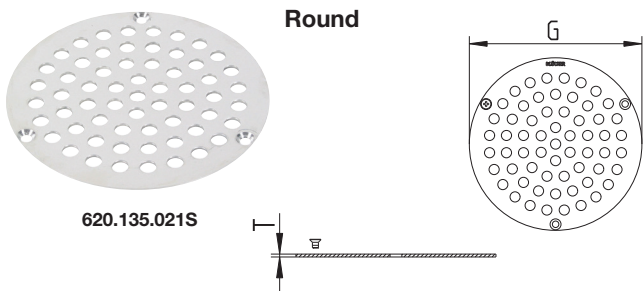

Water Traps — Two-Part Trap, Removable Multi Trap



Model No. 316L / Global Part #	Pipe Size D	H	H5	S	D2	Max Flow GPM (l/s)
502.050.110MS	4-1/4"(108)	3-1/2"(89)	2"(50)	3-3/8"(85)		27(1.7)
503.000.110CR	4-1/4"(108)	4-7/16"(113)	5-11/16"(93)	2"(51)	2-15/16"(75)	19(1.2)

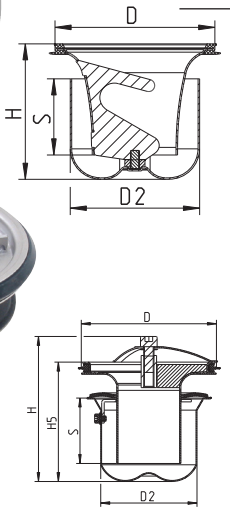

Pre-sloped linear drainage for commercial and industrial applications



WaterLine Shower/Washroom Channel
Trench Drain
Kitchen Channel

Sanitary Applications

- Industrial manufacturing
- Medical facilities
- Hotels and resorts
- Commercial kitchens
- Supermarkets, restaurants, airports, etc.

Special Applications

- Chemical or biohazard environments
- Rubberized or epoxy flooring

Specifications

- 12 ga. (2mm) stainless steel AISI 304 or 316L
- Pre-sloped with longitudinal and cross fall
- ANSI load classifications Light Duty to Extra Heavy Duty
- IAPMO and/or NSF listed



Compliance with NSF/ANSI/3-A 14159-1-
Hygiene Requirements for the Design of
Meat and Poultry Processing Equipment

Pictorial Index

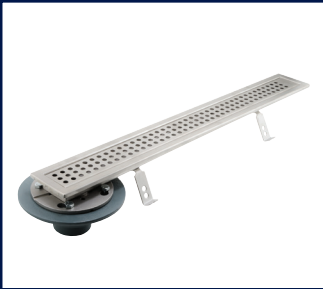

BWC-100
WaterLine Shower Channel



BWS-200
Shower Channel
w/Surface Membrane Clamp



BT6 Series
6" Wide Trench Drain



BTV6 Series
6" Wide Trench Drain
w/Surface Membrane Clamp



BT12 Series
12" Wide Trench Drain



BHG Series
HygienicPro[®] Channel



BTS Series
Slot Channel



BKC-100
16"x16" Kitchen Channel



BKC-200
16"x32" Kitchen Channel



BKC-300
20"x20" Kitchen Channel



BKC-400
20"x40" Kitchen Channel

Installation examples

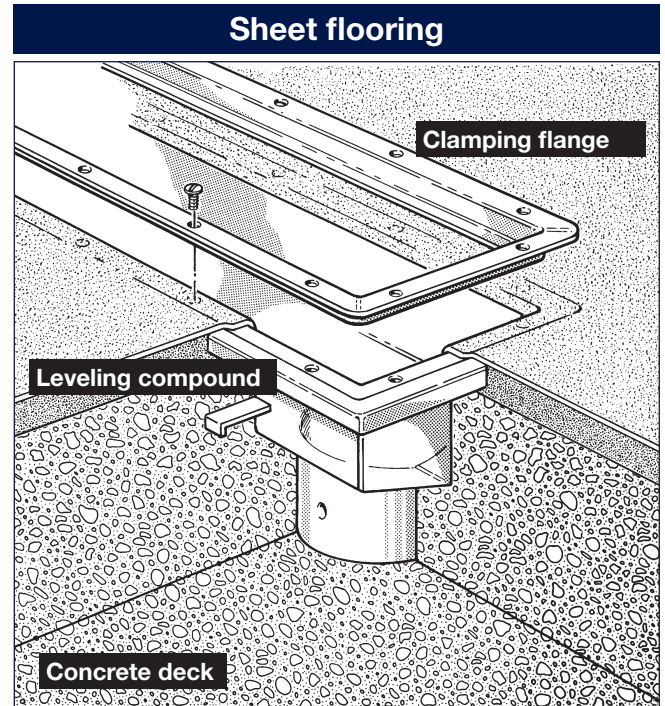
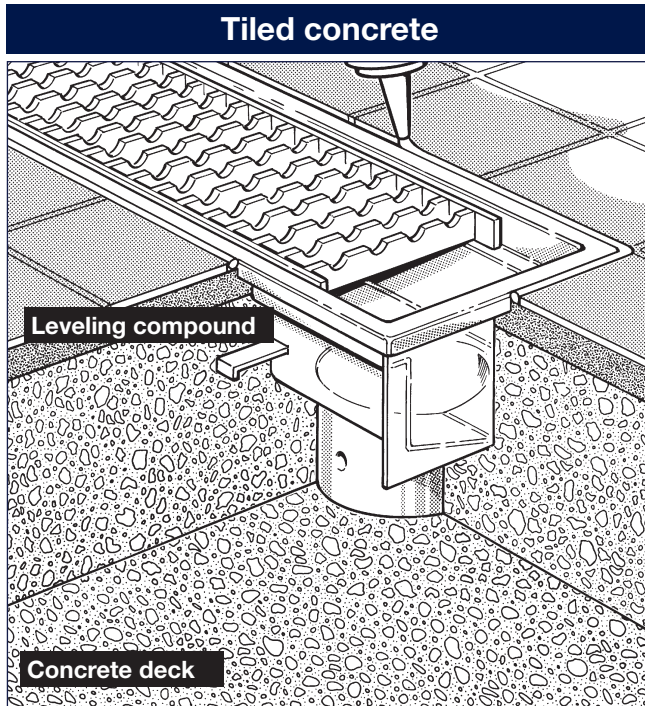

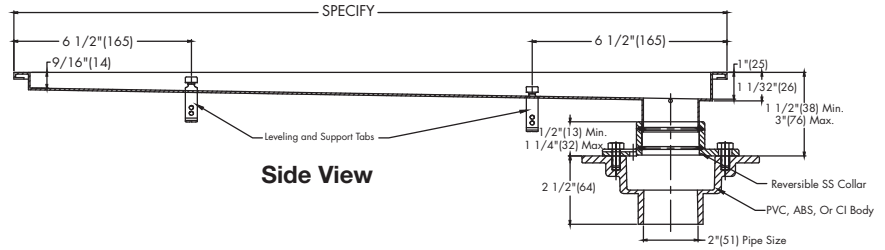
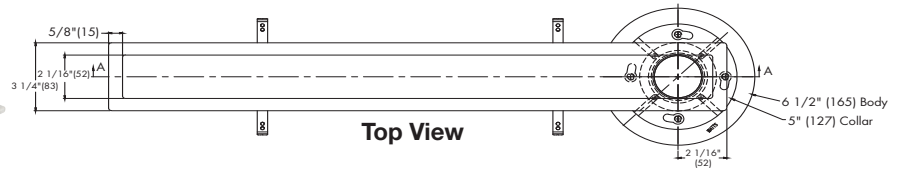

BWC-100 WaterLine Shower/Washroom Channel with Membrane Clamp

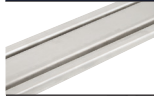

Model No.	Pipe Size	Top Size W x L
BWC-126	2"(50) No Hub	3-1/4"x26" (82x660)
BWC-130	2"(50) No Hub	3-1/4"x30" (82x762)
BWC-136	2"(50) No Hub	3-1/4"x36" (82x914)
BWC-142	2"(50) No Hub	3-1/4"x42" (82x1067)
BWC-148	2"(50) No Hub	3-1/4"x48" (82x1220)
BWC-160	2"(50) No Hub	3-1/4"x60" (82x1524)
BWC-172	2"(50) No Hub	3-1/4"x72" (82x1829)

Optional Connections:		
-60	2" (50)	PVC Socket
-61	2" (50)	ABC Socket
-THD	2" (50)	Threaded

Optional Gratings			
	Suffix	Description	
	-C	Copenhagen	<input type="checkbox"/>
	-Q	Custom (Specify - 100pc Minimum)	<input type="checkbox"/>

BWS-200 WaterLine Channel w/Surface Clamp (for Sheet Flooring)

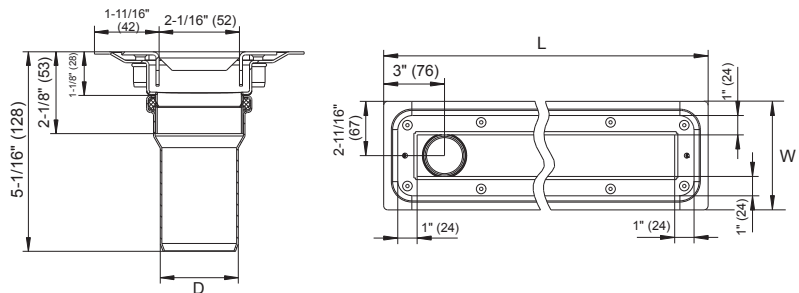

Model No.	Pipe Size D	Top Size W x L
BWS-228	2"(50)	5-3/8"x27-1/2"(135x700)
BWS-232	2"(50)	5-3/8"x31-1/2"(135x800)
BWS-236	2"(50)	5-3/8"x35-1/2"(135x900)
BWS-240	2"(50)	5-3/8"x39-1/2"(135x1000)

BT6 Series Trench Drains

BT6 6" Wide Trench Pre-Sloped Trench Drain with Mesh Grating

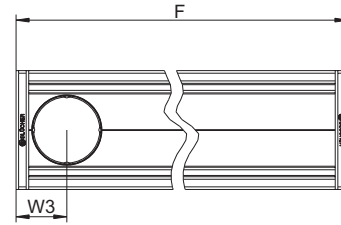
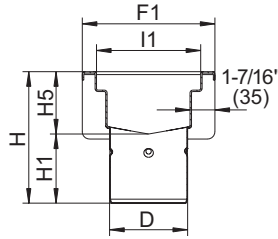

Model No.	Global Part #	Pipe Size D	Length F	F1	H	H1	H5	I1	W3
BT6	670 Series	Specify	Specify	7-3/8"(187)	7-3/8"(186)	3-13/16"(96)	3-9/16"(90)	5-13/16"(147)	3-13/16"(80)

BTV6 6" Wide Pre-Sloped Trench Drain w/Surface Clamp & Mesh Grating (For Sheet Flooring)

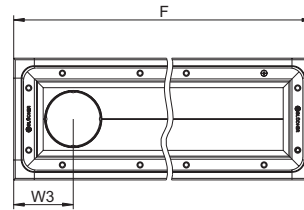
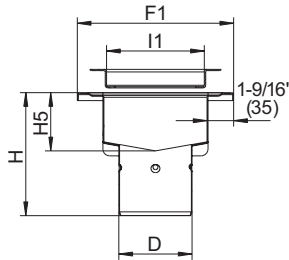

Model No.	Global Part #	Pipe Size D	Length F	F1	H	H5	I1	W3
BTV6	672 Series	Specify	Specify	9-1/4"(235)	7-3/8"(186)	3-9/16"(90)	5-13/16"(147)	4-9/16"(115)

BT12 12" Wide Trench Pre-Sloped Trench Drain with Mesh Grating

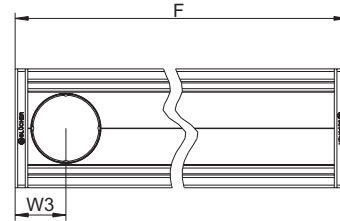
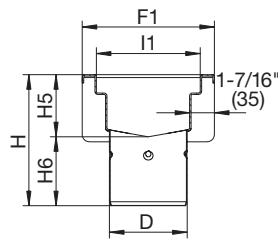

Model No.	Global Part No.	Pipe Size D	Length F	F1	H	H5	H6	I1	W3
BT12	670 Series	Specify	Specify	13-1/4"(337)	7-9/16"(192)	4"(102)	3-9/16"(90)	11-11/16"(297)	4-3/16"(105)

Series BT6 Series Grating Options

Suffix	Description
-HG	Hygienic-Pro
-LG	Ladder
-SG	Slot
-XLG	Extra Heavy Duty Ladder
-SH	Shower

BT6/BT12 Series Options

Suffix	Description
-316	Type 316 Stainless Steel
-B	Sediment Basket
-FC	Outlet w/Membrane Clamp
-LD	Grate Locking Device
-P	Stainless Steel P-Trap

BT12 Series Grating Options

Suffix	Description
-SG	Slot
-XLG	Extra Heavy Duty Ladder

BHG Series Channel

BHG HygienicPro® Channel

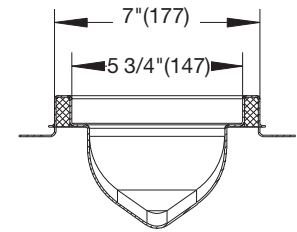
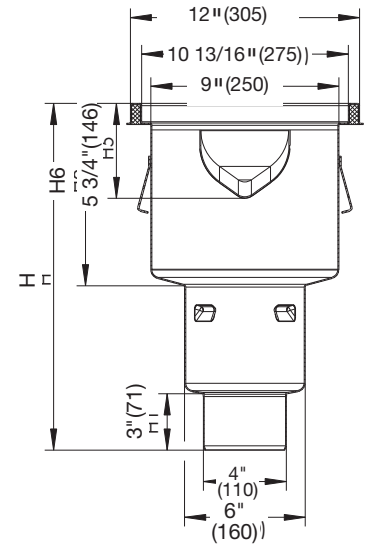
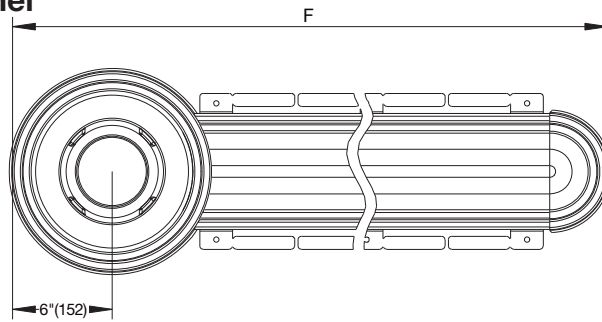

Model No	Style	Length F	H	H6
BHG Series	Low	Specify	15 5/8"(398)*	6 1/8"(155)*
	Medium		18 7/8"(480)*	9 3/8"(237)*
	High		22 1/4"(565)*	12 5/8"(322)*

Series BHG Options	
Suffix	Description
-316	Type 316 Stainless Steel
-B	Sediment Basket
-CO	Center Outlet
-P	Stainless Steel P-Trap

*If Length F is less than 98" (2482 mm) for a center outlet or 49" (1241 mm) for an end outlet, then subtract 3/4" (20 mm) from dimension shown for H and H6.

BTS Series Slot Channel w/Outlet Box

BTS Slot Channel w/Outlet Box

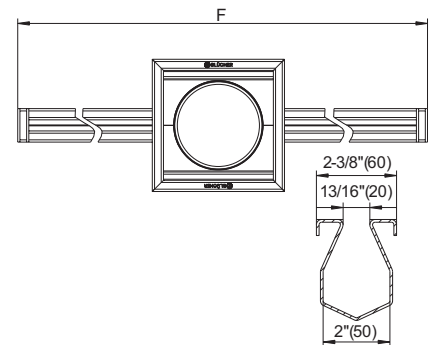
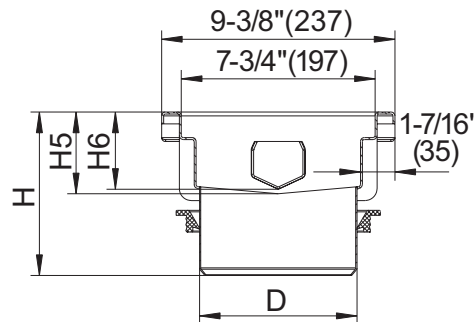
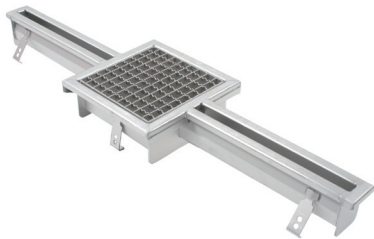

Model No.	Global Part #	Pipe Size D	Length F	H	H5	H6
BTS	673 Series	Specify	Specify	6-9/16"(166)	3-3/8"(85)	3-1/8"(78)

BTS Series Options

Suffix	Description
-316	Type 316 Stainless Steel
-B	Sediment Basket
-LB	Less Outlet Box
-P	Stainless Steel P-Trap

BT Series Trench Drain Gratings

Commercial/Industrial Trench Drain Gratings

Mesh Grating (Standard)

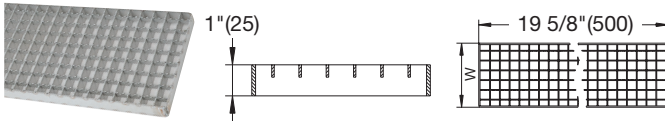

Hygienic-Pro Grating (-HG)

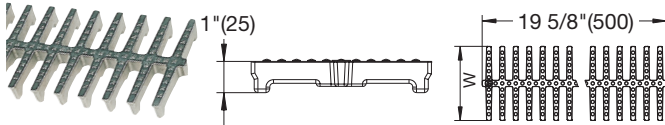

Ladder Grating (-LG)

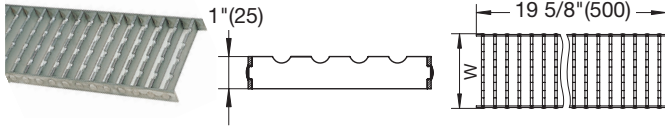

Slot Grating (-SG)

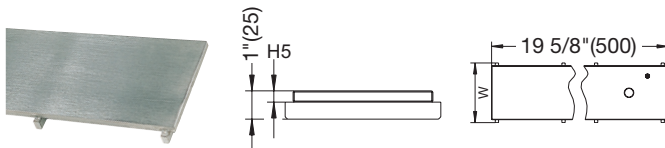

Fully Welded Ladder Grating (-XXLG)

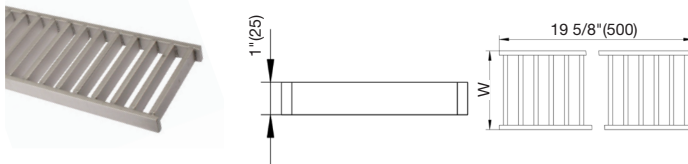

Shower Grating (-SH)

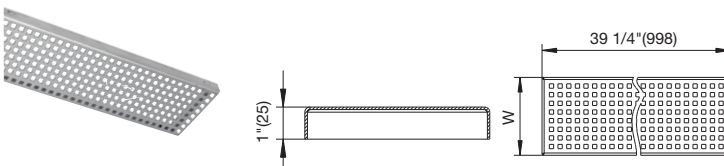

Please see ES-B-Commercial/Industrial Square Gratings & ES-B-Commercial/Industrial Round Gratings for more information.

NOTICE

Load Ratings

Load ratings are based upon maximum anticipated traffic, in accordance with American Standards ASME A112.6.3-2016. See specification pages for specific load rating data.

Product Data

Model No.	Global Part No.	Load Rating ASME A112.6.3-2016	W	H5	R Non-Slip	Free Area
Mesh Grating (Standard)						
BTG-M6 ¹	696.223.144.49	XHD	5-3/4"(145)	N/A	R12	70.70 Sq. In.
BTG-M8 ¹	696.223.194.49	MD	7-11/16"(194)	N/A	R12	119.60 Sq. In.
BTG-M12 ¹	696.223.294.49	LD	11-5/8"(295)	N/A	R12	183.56 Sq. In.
Hygienic-Pro Grating (-HG)						
BTG-H6 ¹	697.250.150.50	SD ²	5-3/4"(145)	N/A	R10	
BTG-H8 ¹	697.250.200.50	SD	7-11/16"(194)	N/A	R10	81.08 Sq. In.
BTG-H12	697.250.300.50	N/A	11-5/8"(295)	N/A	R10	
Ladder Grating (-LG)						
BTG-L6 ¹	697.125.150.50	SD	5-3/4"(145)	N/A	R11	83.03 Sq. In.
BTG-L8 ¹	697.125.200.50	N/A	7-11/16"(194)	N/A	R11	113.57 Sq. In.
BTG-L12	697.125.300.50	N/A	11-5/8"(295)	N/A	R11	171.15 Sq. In.
Slot Grating (-SG)						
BTG-S6 ¹	697.200.150.49	XHD	5-3/4"(145)	7/16"(10)	R10	10.69 Sq. In.
BTG-S8 ¹	697.200.200.50	SD	7-11/16"(194)	7/16"(10)	R10	10.69 Sq. In.
BTG-S12	697.200.300.50	N/A	11-5/8"(295)	7/16"(10)	R10	10.69 Sq. In.
Fully Welded Ladder Grating (-XXLG)						
BTG-XXL6	697.225.150.50	SD	5-3/4"(145)	N/A	R11	
BTG-XXL8	697.225.200.50	SD	7-11/16"(194)	N/A	R11	
BTG-XXL12	697.225.300.50	XHD	11-5/8"(295)	N/A	R11	
Shower Grating (-SH)						
BT6-SH6 ^{1,3}	697.015.150.99	LD	5-3/4"(145)	N/A	R10	23.81 Sq. In.
BT6-SH8 ¹	697.015.300.99	N/A	7-11/16"(194)	N/A	R10	

Notes:

1. Data interpolated from ASME load testing.
2. Grates are ADA compliant per ch. 3 (Paragraph 302.3) of 2010 ADA Standards for Accessible Design. Grates are heel resistant per ASME A112.6.3-2016 Section 5 Paragraph 3.

Approvals



Compliance with NSF/ANSI/3-A 14159-1-Hygiene Requirements for the Design of Meat and Poultry Processing Equipment



Product is certified to the uniform plumbing code ASME A112.6.3

BKC Series Kitchen Channel

BKC-100 16"x16" (400x400) Kitchen Channel with Mesh Grating

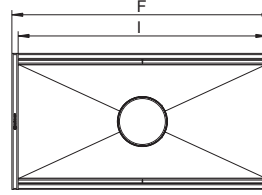
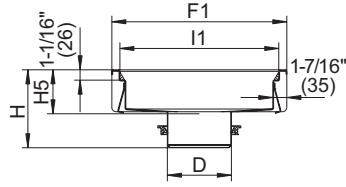
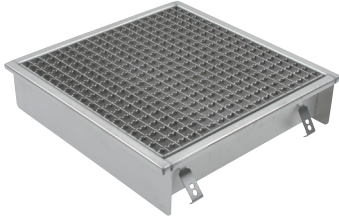

Model No.	Global Part #	Pipe Size D	F	F1	H	Depth H5	I	I1
BKC-104-2	660FH004-06.22	4"(110)	17-3/16"(437)	17-3/16"(437)	6-7/16"(163)	2-3/8"(60)	15-5/8"(397)	15-5/8"(397)
BKC-104-4	660FH004-11.22	4"(110)	17-3/16"(437)	17-3/16"(437)	8-3/8"(213)	4-5/16"(110)	15-5/8"(397)	15-5/8"(397)
BKC-104-6	660FH004-15.22	4"(110)	17-3/16"(437)	17-3/16"(437)	10"(253)	5-7/8"(150)	15-5/8"(397)	15-5/8"(397)
BKC-106-2	660FK004-06.22	6"(160)	17-3/16"(437)	17-3/16"(437)	5-11/16"(145)	2-3/8"(60)	15-5/8"(397)	15-5/8"(397)
BKC-106-4	660FK004-11.22	6"(160)	17-3/16"(437)	17-3/16"(437)	7-11/16"(195)	4-5/16"(110)	15-5/8"(397)	15-5/8"(397)
BKC-106-6	660FK004-15.22	6"(160)	17-3/16"(437)	17-3/16"(437)	9-1/4"(235)	5-7/8"(150)	15-5/8"(397)	15-5/8"(397)

BKC-200 16"x32" (400x800) Kitchen Channel with Mesh Grating

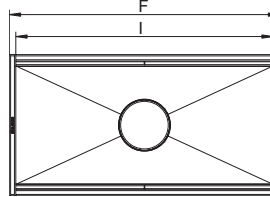
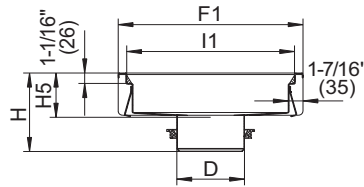
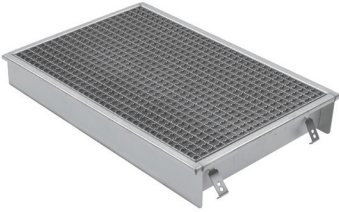

Model No.	Global Part #	Pipe Size D	F	F1	H	Depth H5	I	I1
BKC-204-2	660FH008-06.22	4"(110)	33"(837)	17-3/16"(437)	6-7/16"(163)	2-3/8"(60)	31-3/8"(797)	15-5/8"(397)
BKC-204-4	660FH008-11.22	4"(110)	33"(837)	17-3/16"(437)	8-3/8"(213)	4-5/16"(110)	31-3/8"(797)	15-5/8"(397)
BKC-204-6	660FH008-15.22	4"(110)	33"(837)	17-3/16"(437)	10"(253)	5-7/8"(150)	31-3/8"(797)	15-5/8"(397)
BKC-206-2	660FK008-06.22	6"(160)	33"(837)	17-3/16"(437)	5-11/16"(145)	2-3/8"(60)	31-3/8"(797)	15-5/8"(397)
BKC-206-4	660FK008-11.22	6"(160)	33"(837)	17-3/16"(437)	7-11/16"(195)	4-5/16"(110)	31-3/8"(797)	15-5/8"(397)
BKC-206-6	660FK008-15.22	6"(160)	33"(837)	17-3/16"(437)	9-1/4"(235)	5-7/8"(150)	31-3/8"(797)	15-5/8"(397)

BKC-300 20"x20" (500x500) Kitchen Channel with Mesh Grating

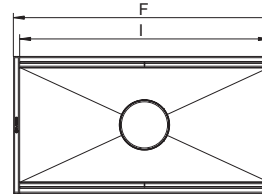
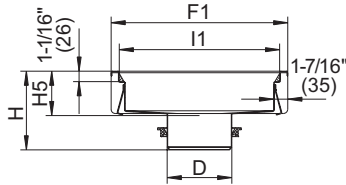
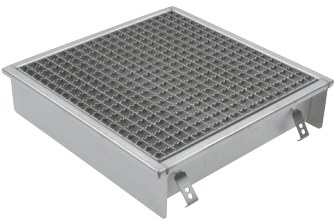

Model No.	Global Part #	Pipe Size D	F	F1	H	Depth H5	I	I1
BKC-304-2	660GH005-06.22	4"(110)	21-1/8"(537)	21-1/8"(537)	6-7/16"(163)	2-3/8"(60)	19-9/16"(497)	19-9/16"(497)
BKC-304-4	660GH005-11.22	4"(110)	21-1/8"(537)	21-1/8"(537)	8-3/8"(213)	4-5/16"(110)	19-9/16"(497)	19-9/16"(497)
BKC-304-6	660GH005-15.22	4"(110)	21-1/8"(537)	21-1/8"(537)	10"(253)	5-7/8"(150)	19-9/16"(497)	19-9/16"(497)
BKC-306-2	660GK005-06.22	6"(160)	21-1/8"(537)	21-1/8"(537)	5-11/16"(145)	2-3/8"(60)	19-9/16"(497)	19-9/16"(497)
BKC-306-4	660GK005-11.22	6"(160)	21-1/8"(537)	21-1/8"(537)	7-11/16"(195)	4-5/16"(110)	19-9/16"(497)	19-9/16"(497)
BKC-306-6	660GH005-15.22	6"(160)	21-1/8"(537)	21-1/8"(537)	9-1/4"(235)	5-7/8"(150)	19-9/16"(497)	19-9/16"(497)

BKC Series Kitchen Channel

BKC-400 20"x40" (500x1000) Kitchen Channel with Mesh Grating

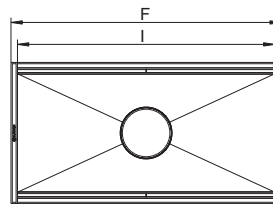
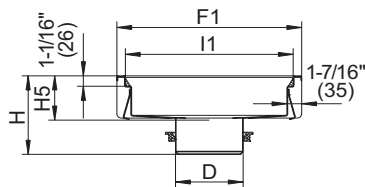
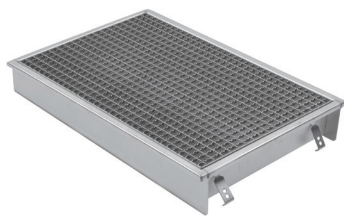

Model No.	Global Part #	Pipe Size D	F	F1	H	Depth H5	I	I1
BKC-404-6	660GH010-15.22	4"(110)	40-13/16"(1037)	21-1/8"(537)	10"(253)	5-7/8"(150)	39-1/4"(997)	19-9/16"(497)
BKC-406-2	660GK010-06.22	6"(160)	40-13/16"(1037)	21-1/8"(537)	5-11/16"(145)	2-3/8"(60)	39-1/4"(997)	19-9/16"(497)
BKC-406-4	660GK010-11.22	6"(160)	40-13/16"(1037)	21-1/8"(537)	7-11/16"(195)	4-5/16"(110)	39-1/4"(997)	19-9/16"(497)
BKC-406-6	660GK010-15.22	6"(160)	40-13/16"(1037)	21-1/8"(537)	9-1/4"(235)	5-7/8"(150)	39-1/4"(997)	19-9/16"(497)

BKC Options	
Suffix	Description
-LG	Heavy Duty Ladder Grating
-316	Type 316 Stainless Steel
-B	Sediment Basket
-FC	Outlet w/Membrane clamp
-P	Stainless Steel P-Trap

Heavy Duty Ladder Grating (-LG)





A WATTS Brand