

Specification Sheet

525.180.075 S S-TRAP 180°

- Diameter: Ø3 inch
- Water seal height = 3-1/4 inch
- Stainless steel: AISI316L/EN1.4404

Product Codes

EAN: 5705499114102
VVS Number:
RSK Number:
NRF Number: 3395048
LVI Number:

Specification

Angle (°): 180
Length (mm): 93
Material: AISI 316L
Material (EN): EN 1.4404
Outlet dia. (mm): 75
Outlet Diameter (Inch): 3
Type: Traps
Water Seal Height (mm): 81
Weight (kg): 1
Weight (lbs): 2.2

Approvals

W AUS - WMKT00204 - 18B

Bureau Veritas, 02375-H0
ABS - 18-LD1716353-PDA
PL - Hygienic Certificate - All products
KR - Type Approval CPH42135-PE001
Bureau Veritas - 03456-H0

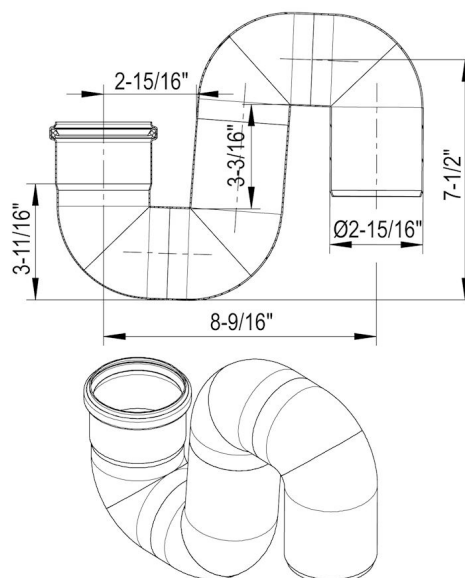

BLÜCHER®